



**penta** s.r.l.

VALVOLE A SFERA A SEGGI METALLICI  
METAL SEATED BALL VALVES



*CATALOGO GENERALE*  
*GENERAL CATALOGUE*

MADE IN ITALY





Indice / Index

	• <b>Profilo aziendale - Company profile</b> .....	pag.	2-3
	• <b>PENTAFITE</b>		
	Cosa è pentafite - <i>What is pentafite</i> .....	pag.	4
	• <b>Mod. AP</b> .....	pag.	7
	AP10NU .....	pag.	12
	AP10NB .....	pag.	14
	AP10HP.....	pag.	16
	AP11N .....	pag.	18
	AP20P.....	pag.	20
	AP60.....	pag.	22
	AP64.....	pag.	24
	AP68.....	pag.	26
	AP606.....	pag.	28
	AP609.....	pag.	30
	AP50.....	pag.	32
	AP54.....	pag.	34
	AP506.....	pag.	36
	APT2 .....	pag.	38
	APT3 .....	pag.	40
	Accessori - <i>Accessories</i> .....	pag.	42
	• <b>Mod. WSS</b> .....	pag.	43
	• <b>Mod. P40</b> .....	pag.	49
	P40.....	pag.	50
	Accessori - <i>Accessories</i> .....	pag.	54
	• <b>Mod. SAT</b> .....	pag.	55
	Tipica valvola SAT Trunnion - <i>Typical SAT with Trunnion mounted ball</i> .....	pag.	60
	Tipica valvola SAT a sfera flottante - <i>Typical SAT with floating ball</i> .....	pag.	61
	• <b>Mod. SAT CRIO</b> .....	pag.	63
	Tipica valvola CRIO flottante - <i>Typical SAT CRIO with floating ball</i> .....	pag.	68
	Tipica valvola SAT CRIO trunnion - <i>Typical SAT CRIO with trunnion ball</i> .....	pag.	69
	• <b>Mod. SAT 3</b> .....	pag.	71
	• <b>Mod. MULTIPORT</b> .....	pag.	75
	Tipica valvola 3-VIE 90° Trunnion con passaggio a "L" oppure a "T" <i>Typical 3-WAY 90° Trunnion mounted ball with "L" port or "T" port</i> .....	pag.	80
	• <b>PROGETTI SPECIALI - SPECIAL DESIGNS</b> .....	pag.	81
	• <b>Referenze - Reference</b> .....	pag.	85



## **TECNOLOGIA** TECHNOLOGY

Penta ha sviluppato tecnologie proprietarie uniche nel settore:

- l'unico materiale metallico per sedi auto-lubrificante PENTAFITE
- speciali guarnizioni in Grafoil adatte anche ad alte pressioni completamente realizzate internamente

*Penta has developed proprietary technologies on:*

- *Valve metallic seating with the unique self lubricating PENTAFITE material*
- *In-shop manufactured special high pressure resistant Grafoil gaskets*

## **ESPERIENZA** EXPERIENCE

Penta è nata nel 1977 per la produzione di valvole a sfera a sedi metalliche per condizioni critiche:

- alta temperatura (fino a 700°C)
- bassa temperatura (fino a -196°C)
- servizi abrasivi
- servizi pericolosi.

*Penta started in 1977 with the production of Metal Seated Ball Valves for critical conditions:*

- *high temperatures (up to 700°C)*
- *low temperatures (down to -196°C)*
- *abrasive services*
- *dangerous services*

## **PASSIONE** PASSION

Una azienda a completa conduzione privata e con uno staff giovane e preparato tecnicamente

*A private owned company with young but technical prepared staff.*

## **ASSISTENZA** ASSISTANCE

Cooperiamo con i Clienti per identificare il modello e la costruzione più adatte alle reali condizioni di esercizio.

Penta mantiene tutte le informazioni relative a qualsiasi prodotto per una durata di 20 anni così come la disponibilità di ricambi. Le nostre officine sono sempre a disposizione per effettuare manutenzioni al nostro interno di nostri prodotti.

*We cooperate with Customers to identify best model/construction with reference to real working conditions.*

*Penta keeps all informations related to any product available for 20 years as like as spares availability. Our workshop is always available for in-shop maintenance of our products.*

## **QUALITÀ** QUALITY

Tutte le valvole Penta sono testate con:

- Prova Idraulica Corpo
- Prova Idraulica Sedi
- Prova Pneumatica Sedi (6 bar)

per verificare la Tenuta Perfetta (nessuna perdita visibile è ammessa).

Penta è certificata certificate ISO 9001-2008 e ISO 14001-2004

*All Penta valves are pressure tested as follow:*

- *high pressure body hydrotest*
- *high pressure seat hydrotest*
- *low pressure seat air test (6 bar)*

*No Visible Leakage is allowed during all above tests.*

*Penta is an ISO 9001-2008 and ISO 14001-2004 certified company*



## **FLESSIBILITÀ** FLEXIBILITY

Dare rispondenza a qualsiasi requisito specifico è una delle nostre principali strategie di vendita

*Answering specific Customer requirements is one of the purpose of our selling strategy.*

## **AFFIDABILITÀ** RELIABILITY

Attività di ricerca sono costantemente realizzate allo scopo di allungare la vita in servizio dei nostri prodotti.

I pezzi di ricambio sono mantenuti disponibili per tutte le valvole prodotte dal 1982.

*Continuous research activities are developed in order to elongate our product life under service. Spare parts are available for all those valves produced starting from 1982.*



Azienda con sistema  
Qualità certificato.  
Certificato  
Nr. 50 100 6269  
Rev. 05



Azienda con sistema di  
Gestione Ambientale  
certificato. Certificato  
Nr. 50 100 12565



Directive 2014/68/UE  
"PED"



II2G c IIC TX  
II2D c IIC TX  
Directive 2014/34/UE  
"ATEX"



# La tecnologia PENTAFITE

## COSA E' PENTAFITE

PENTAFITE è un composto a matrice metallica con dispersione di lubrificante solido. E' ottenuto attraverso un processo di produzione assimilabile alla sinterizzazione con il quale, partendo dalle polveri dei diversi costituenti, si arriva ad ottenere anelli metallici destinati a divenire l'inserto di tenuta in valvole a sfera per servizi in alta temperatura, alte pressioni o con combinazioni pressione/temperatura superiori ai limiti sopportabili dai materiali polimerici.

## WHAT IS PENTAFITE

PENTAFITE is a metallic compound with metallic matrix and fine dispersion of solid lubricant inside. It is obtained by a manufacturing process similar to sintering with which, starting from fine powders of the single component, is possible to produce the metallic rings that form the seat insert for our metal seated ball valves for services with high temperature, high pressure or with combination pressure/temperature higher than tolerable limits for polymeric material.

### SEGGIO IN PENTAFITE PENTAFITE SEAT ASSEMBLY



### COMPOSIZIONI DISPONIBILI PER I SEGGI - AVAILABLE SEAT MATERIAL COMPOSITIONS

Material <i>Material</i>	Matrice metallica <i>Metallic matrix</i>	Lubrificante solido <i>Solid lubricant</i>	Temperature di lavoro <i>Working temperature</i>	Pressioni di lavoro <i>Working pressure</i>	Dimensioni <i>Valve size</i>
PENTAFITE serie SXX (Base Nickel - <i>Nickel base</i> )	Nickel	Grafite <i>Graphite or MoS2</i>	-100°C / +780°C	ANSI 150 - 2500 API 10000 PN 10 - 420	½" - 20"
PENTAFITE serie RXX (Base Rame - <i>Rame base</i> )	Rame - <i>Copper</i>	Grafite - <i>Graphite</i>	-100°C / +500°C	ANSI 150 - 2500 PN 10 - 420	½" - 20"
PENTAFITE serie BXX (Base Carbone - <i>Carbon base</i> )	Carbone - <i>Carbon</i>	Grafite - <i>Graphite</i>	Amb. / +400°C PN 10 - 40	ANSI 150 - 300	½" - 4"

# The Pentafite Seat technology



## CARATTERISTICHE MECCANICHE E FISICHE - MECHANICAL AND PHYSICAL FEATURES

Coefficiente di attrito su superficie rettificata ed indurita ( 1500 HV min.) (PENTAFITE serie SXX) <i>Friction factor against ground surface hardened to 1500 HV min. (SXX PENTAFITE Serie)</i>	0,2
Massima pressione specifica di contatto <i>Maximum working specific pressure</i>	30 Kg/mm <sup>2</sup>
Massima temperatura di lavoro <i>Maximum working temperature</i>	780°C
Massima pressione di esercizio <i>Maximum working pressure</i>	720 bar
Coefficiente di dilatazione termica 0°-200°C <i>Thermal expansion 0°-200°C</i>	14 x 10 <sup>-6</sup>

Aspetto della microstruttura di sedgio in PENTAFITE (ingrandimento 100x)  
*100x magnification of PENTAFITE cross-section*



Grafico Pressioni/Temperature max. di lavoro per sedi realizzate in PENTAFITE  
*Pressure/Temperature working range for seats manufactured in PENTAFITE*



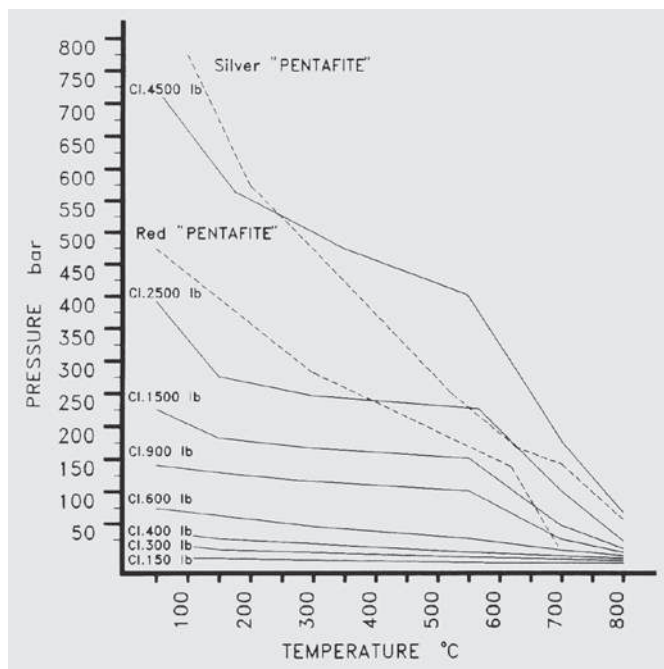
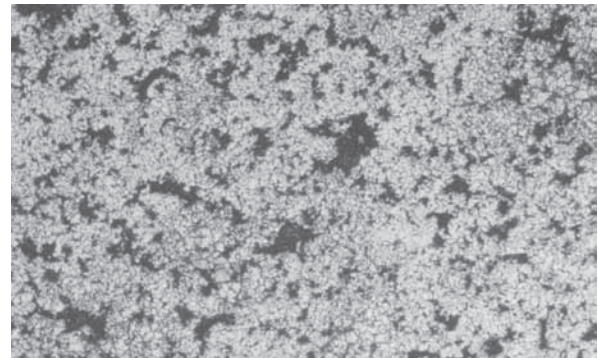

## Proprietà sedi PENTAFITE PENTAFITE seat properties

### PRINCIPALI PROPRIETÀ DELLE SEDI METALLICHE IN PENTAFITE

#### Tenuta Perfetta

Le caratteristiche elasto-plastiche del materiale PENTAFITE permettono l'automatico adattamento dei seggi alla forma della sfera, annullando le imperfezioni di lavorazione. In questo modo è possibile eliminare ogni possibilità di fuga ed ottenere la perfetta tenuta dell'accoppiamento seggio-sfera.

#### Basse Coppie di Manovra

La presenza di lubrificante solido all'interno della matrice metallica permette di ridurre il coefficiente di attrito tra sede e sfera, riducendo al contempo le coppie di manovra della valvola. Per lo stesso motivo non sono possibili grippaggi, nemmeno in presenza di alte temperature di esercizio o alte pressioni specifiche di contatto.

#### Facilità di manutenzione

Non essendo necessarie lavorazioni di adattamento tra seggio e sfera (il seggio non deve essere lappato sulla sfera prima del montaggio) risultano semplificati gli interventi di montaggio o manutenzione delle valvole qualora equipaggiate con seggi in PENTAFITE.

#### Tenuta perfetta con gas

Essendo possibile il raggiungimento di elevate pressioni specifiche di contatto tra seggio e sfera grazie alla presenza del lubrificante solido disperso nella matrice metallica, l'accoppiamento sede-sfera è in grado di trattenere gas ad elevate pressioni.

### MOST IMPORTANT PROPERTIES OF PENTAFITE METAL SEATS

#### Perfect Tightness

*Elastic properties of PENTAFITE seat material allow the automatic adaptation of seats against ball shape, eliminating machining imperfections. This way it is possible to eliminate any possible leak-point and to meet the perfect tightness.*

#### Low valve torque

*The presence of the solid lubricant dispersion inside the metallic matrix, reduces the seat to ball friction factor and also the valve torque. For the same reason seizure or galling between seat and ball surfaces are eliminated even when the working temperature is high.*

#### Easy maintenance

*Because it is not necessary for additional machining to adapt seats against the ball (You do not have to lap the seat against to the ball) valve assembly and maintenance are very easy when PENTAFITE metal seats are used.*

#### Gas tightness

*The presence of the solid lubricant inside allows the PENTAFITE material to reach very high working specific pressures resulting in perfect tightness when high pressure gases must be stopped.*

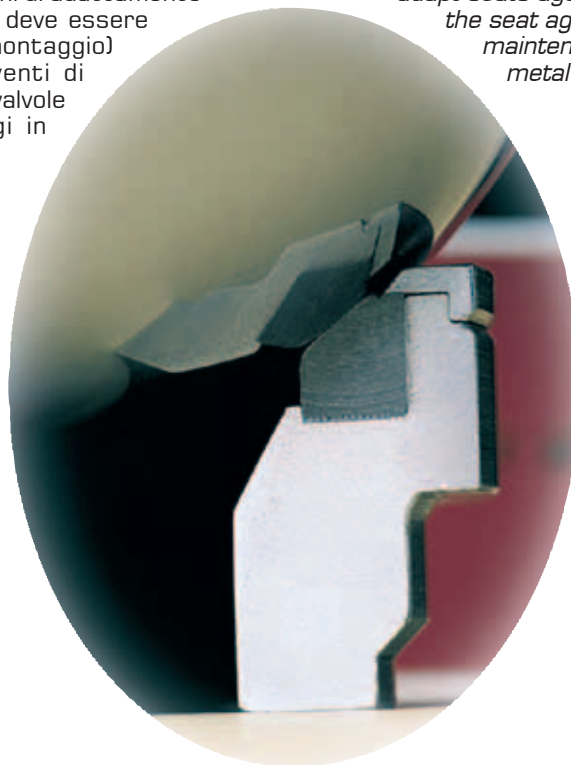



**MODELLO / MODEL**

**AP**

**Fire-Safe**  
Certificate  
API 607 V ED.  
ISO 10497

**CRN**  
Certificate

**Ta-Luft**  
Approved  
(c/w 100 mm stem elongation)

**EAC**  
Eurasian Conformity

**CE**  
Directive 2014/68/UE  
"PED"

**Ex** II2G c IIC TX  
II2D c IIC TX  
Directive 2014/34/UE  
"ATEX"



**Il modello AP combina:**

- la affidabilità e la capacità di risolvere i problemi della intercettazione di fluidi ad alta temperatura tipiche delle valvole a seggi metallici in PENTAFITE prodotte da PENTA

con

- la qualità di una produzione di grande serie caratteristiche dei modelli di produzione ALFA VALVOLE.

Tutte le valvole della serie AP sono equipaggiate con sedi metalliche in PENTAFITE che permettono la realizzazione di valvole a sfera a seggi metallici con PREDITA ZERO e di facile manutenzione, non necessitando di lavoro di adattamento tra sedi e sfere, grazie alle particolari caratteristiche elasto-plastiche del materiale dei seggi PENTAFITE.

La stessa attenzione è posta alla verifica del grado di tenuta verso l'esterno mediante la certificazione RWTUV della rispondenza ai limiti imposti dal regolamento TA-LUFT tedesco.

**The AP series combines:**

- the well known reliability and capability to solve the problem of high temperature fluid handling typical of all PENTA metal seated ball valves,

and

- the quality of the mass produced standard ALFA VALVOLE models.

All valves of AP series are equipped with metallic seats in PENTAFITE to allow the manufacturing of metal seated ball valves with absolutely ZERO LEAKAGE and easy maintenance without necessity of additional lapping of the seats to the ball, typical of PENTAFITE elastic properties.

The same attention is put on the verification of class of tightness toward the outside by RWTUV referred to the limits imposed from the German regulation TA-LUFT.



# VALVOLE A SFERA A SEGGI METALLICI METAL SEATED BALL VALVES



## Tenuta stelo

Il sistema a doppia molla e dadi di serraggio consente di fornire il corretto precarico alle tenute stelo, di recuperare usure e differenziali di dilatazione tra stelo e corpo.

## Stem tightness

*The double spring system with loading nuts, allows the correct stem gasket pre-loading and the adjustment to recuperate wearing and clearance for different thermal dilation between stem and body.*

## Guarnizioni

Sono utilizzate esclusivamente guarnizioni in Grafoil® resistenti alle alte temperature; nessun materiale polimerico è impiegato.

## Gasket

*Only Grafoil® gaskets are used, inherently resistant to high temperatures; no polymers are used.*

## Stelo

Gli steli sono 100% sovradimensionati rispetto alla coppia attesa al max. DP di rating.

## Stem

*Stem are 100% oversized against expected torque at max. rated DP.*

## Flange - Bulloneria

Tutti gli accoppiamenti flangiati sono dimensionati secondo ASME VIII Div. 1.

## Bolting and Flanges

*All flanges connections are designed according to ASME VIII Div. 1*

## Sfera

Sfere rettificate ad alta precisione sono prodotte internamente e quindi indurite superficialmente con riporti a tecnologia avanzata.

## Ball

*Very high precision ground balls are produced inside and then hard coated with most advanced system.*

## Seggi

I seggi metallici sono precaricati con molle per una perfetta tenuta alle basse pressioni, per recuperare l'usura e le differenti dilatazioni termiche tra i diversi componenti interni.

## Seats

*Metallic seats are pre-loading with springs for a perfect low-pressure bubble tightness and to recuperate life wearing and different thermal dilatation between internals.*

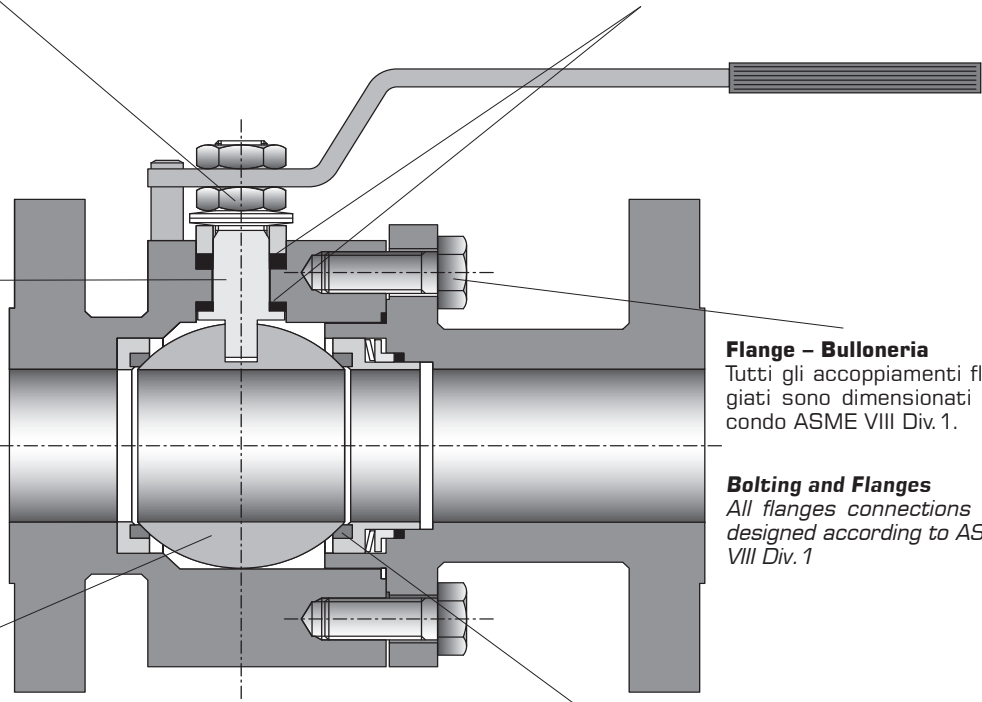



<b>MATERIALI DISPONIBILI PER I SEGGI - AVAILABLE SEAT MATERIAL</b>				
Codice Code	Materiale Material	Durezza Hardness	Temperatura di lavoro Working temperature	Servizio Service Limits
<b>S01</b>	<b>SILVER PENTAFITE</b> (Nickel + Graphite )	120 HB	-100°C / +780°C (-148°F / +1436°F)	For clean services both liquid or gas. For use with <b>HTC, HTCEN, HCR, WC, CRC, ST6</b> ball coated
<b>R01</b>	<b>RED PENTAFITE</b> (Cu + Graphite )	100 HB	-100°C / +500°C (-148°F / +932°F)	For clean services both liquid or gas. Lower friction factors in dry gas or steam service. For use with <b>HTC, HTCEN, HCR, ST6</b> ball coated
<b>B01</b>	<b>BLACK PENTAFITE</b> (Carbon + Graphite )	80 HB	Amb. / +400°C (Amb. / +752°F)	For low pressure specific services where <b>S01</b> and <b>R01</b> cannot be used due to corrosion problems. A ball coat is not strictly necessary and should be evaluated time to time
<b>WC</b>	<b>CARBURO DI TUNGSTENO</b> <i>Tungsten Carbide Coat</i> (Detonation Gun/HVOF)	1100 HV	Amb. / +350°C ( Amb. / +662°F )	For liquid or gas services with high presence of solids. Not suitable when small presence of caustic soda is expected. For use with WC ball coat
<b>ST6</b>	<b>STELLITE Gr.6</b> (Detonation Gun/HVOF)	1000 HV	Amb. / +350°C ( Amb. / +662°F )	For liquid or gas services with small presence of solids. Suitable when small presence of caustic soda is expected. Best on dry gas or steam services. For use with <b>WC, CRC</b> ball coat
<b>CRC</b>	<b>CARBURO DI CROMO</b> <i>Chrome Carbide</i> (Detonation Gun)	800 HV	Amb. / +750°C ( Amb. / +1382°F )	For liquid or gas services with small presence of solids. Not suitable when small presence of caustic soda is expected.
<b>PK1</b>	<b>PEEK</b> (Polietheretherketone)		-100°C. / +240°C (-148°F / +464°F)	For clean liquid or gas services with high frequency of valve operation.
<b>RPTFE</b>	<b>PTFE RINFORZATO VETRO/GARFITE</b> (Glass/Graphite reinforces PTFE)		-100°C/+220°C (-148°F/+428°F)	For clean liquid or gas services with high frequency of valve operation.

<b>MATERIALI DISPONIBILI PER RIVESTIMENTO SFERE - AVAILABLE BALL COATING MATERIALS</b>				
Codice Code	Materiale Material	Durezza Hardness	Temperatura di lavoro Working temperature	Servizio Service Limits
<b>HTC</b>	<b>NITRURI DI TITANIO</b> <i>Titanium Nitride (PVD)</i>	2500 HV	-100°C / +600°C ( -148°F / +1112°F )	For clean services both liquid or gas. For gas and steam up to 180°C
<b>HTCN</b>	<b>CARBO-NITRURI DI TITANIO</b> <i>Carbo-Titanium Nitride (PVD)</i>	3500 HV	-100°C / +400°C ( -148°F / +752°F )	For liquid or gas services with small presence of solids. For gas and steam up to 180°C
<b>HCR</b>	<b>NITRURI DI CROMO</b> <i>Chrome- Nitride (PVD)</i>	3000 HV	Amb. / +750°C ( Amb. / +1382°F )	For clean services both liquid or gas. Best on oxidizing services
<b>WC</b>	<b>CARBURO DI TUNGSTENO</b> <i>Tungsten Carbide</i> (Detonation Gun/HVOF)	1100 HV	Amb. / +350°C ( Amb. / +662°F )	For liquid or gas services with high presence of solids. Not suitable when small presence of caustic soda is expected.
<b>CRC</b>	<b>CARBURO DI CROMO</b> <i>Chrome Carbide</i> (Detonation Gun/HVOF)	800 HV	Amb. / +750°C ( Amb. / +1382°F )	For liquid or gas services with small presence of solids. Not suitable when small presence of caustic soda is expected.
<b>ST6</b>	<b>STELLITE GR.6</b> (Detonation Gun/HVOF)	1000 HV	Amb. / +350°C ( Amb. / +662°F )	For liquid or gas services with small presence of solids. Suitable when small presence of caustic soda is expected. Best on dry or steam services.

**GRADO DI TENUTA - TIGHTNESS**

Tutte le valvole PENTA modello AP sono collaudate per verificarne la TENUTA PERFETTA (perdita zero alla prova idraulica dei seggi secondo ANSI B16.34 e a 6 bar con aria).

All PENTA valves AP model are tested to verify their BUBBLE TIGHTNESS (no visible leakage during hydraulic seat test according to ANSI B 16.34 and during low pressure air seats test at 100 psi)

# VALVOLE A SFERA A SEGGI METALLICI METAL SEATED BALL VALVES



## INTERVALLO DI PRODUZIONE - PRODUCTION RANGE

### CLASSI - PRESSURE CLASSES

ANSI B 16.34	150		300		600		800		900		1500	
PN	16 - 25		40 - 50		64 - 100				160		250	
	F	T	F	T	F	T	F	T	F	T	F	T
Modelli Models	AP54 AP64 AP68 AP10N AP11N	APT2	AP50 AP60 AP10N AP11N	APT2	AP506 AP606 AP10HP	APT2	AP20P		AP609	APT2	AP615	APT2
DN												
1/2"												
3/4"												
1"												
1 1/4"												
1 1/2"												
2"												
2 1/2"												
3"												
4"												
6"												
8" RB <sup>(1)</sup>												

F = Sfera flottante - Floating ball

T = Sfera vincolata - Trunnion mounted ball

<sup>(1)</sup> solo AP50 e AP54 - AP50 and AP54 only

## VERSIONI DISPONIBILI - AVAILABLE VERSIONS

AP10N  
AP10HP Valvola a corpo piatto a sfera flottante, completamente smontabile per manutenzioni  
Wafer ball valve floating ball, fully replaceable seats

AP11N Valvola a corpo piatto completamente smontabile per manutenzioni con camicia di riscaldamento integrale  
Wafer ball valve fully detachable for maintenance with integral heating jacket

AP20P Valvola con corpo in due pezzi avvitati a sfera flottante  
Ball valve with two pieces screwed body and floating ball

AP50  
AP54  
AP506  
AP60  
AP64  
AP68  
AP606  
AP609 Valvola Split Body a sfera flottante, interamente smontabile (per la sostituzione di seggi e guarnizioni)  
Split Body valve, floating ball, with fully replaceable seats

APT2 Valvola split body a sfera trunnion, interamente smontabile (per la sostituzione di seggi e guarnizioni)  
Split body valve, trunnion mounted ball, with fully replaceable seats

APT3 valvola Split Body 3 pezzi trunnion, interamente smontabile per la sostituzione di seggi e guarnizioni  
Split Body valve 3 pieces, trunnion mounted ball, with fully replaceable seats and gaskets.

## OPERATORI DISPONIBILI - AVAILABLE OPERATORS

- Riduttori manuali - Manual gears
- Attuatori pneumatici a semplice o doppio effetto - Single or double acting pneumatic actuators
- Attuatori elettrici - Electric actuator
- Attuatori idraulici - Hydraulic actuators
- Leva con lucchettaggio - Lever c/w locking device



Dimensionamento <i>Design</i>	ASME B16.34 / EN 12569 / API 608 / EN 17292 ASME VIII DIV.1 / EN 12516-1
Estremità flangiate <i>Flanged ends</i>	ASME B16.5 Cl.150 / 300 EN 1092-1 PN 10/16/25/40 DIN 2632 / 2633 / 2634 / 2635
Collaudo <i>Testing</i>	ASME B16.104 API 598 EN 12266-I ISO 5208 BS 6755-I

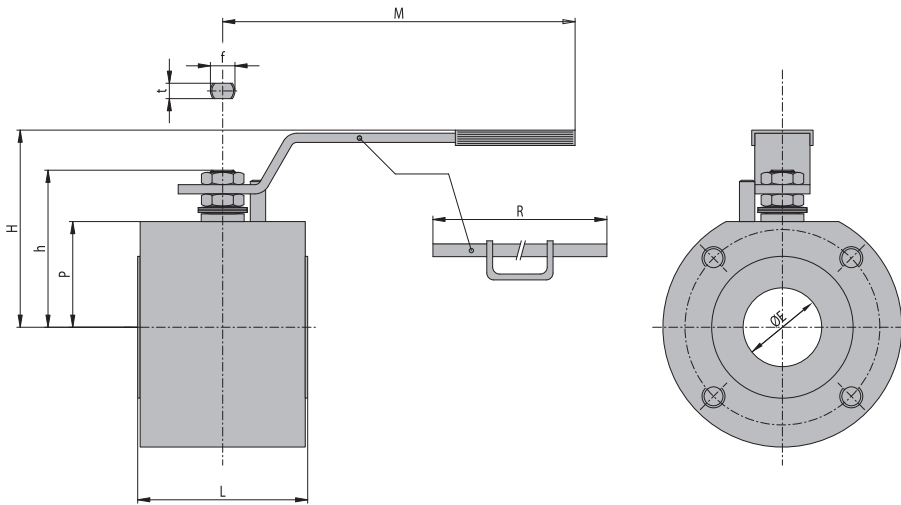

Dimensioni - *outline dimensions*

DN	15	20	25	32	40	50	65	80	100	150
Ø"	1/2"	3/4"	1"	1 1/4"	1 1/2"	2"	2 1/2"	3"	4"	6"
ØE	14	19	24	29	38	48	64	76	95	152
L	36	39	43	51	63	83	120	120	152	243/255*
M	145	145	180	180	275	275	380	380	440	— <sup>(1)</sup>
R	—	—	—	—	—	—	—	—	500	800
H	64	66	85	90	118	126	139	144	200	265
h	52	55	70	73	96	101	122	128	157	220
P	33	36	43	48	63	68.5	82	88.5	111	145
F/t	10/6	10/6	12/8	12/8	16/10	16/10	22/14	22/14	30/18	45/30
Kg	1.5	2	2.7	4	6.5	9	16	20.5	42	80
ISO5211	F03	F03	F03	F03	F05	F05	F07	F07	F10	F14

\* PN25-40/ASME 300 RF

<sup>(1)</sup> È raccomandato riduttore manuale - *Manual gear recommended*

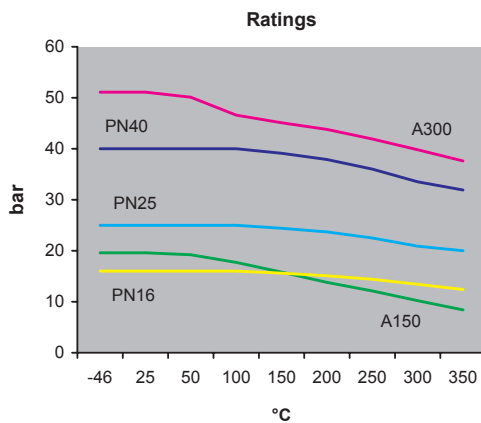

# VALVOLE A SFERA FLOTTANTE A SEGGI METALLICI METAL SEATED FLOATING BALL VALVES



AP

UNI-DIRECTIONAL

-46 °C +400 °C

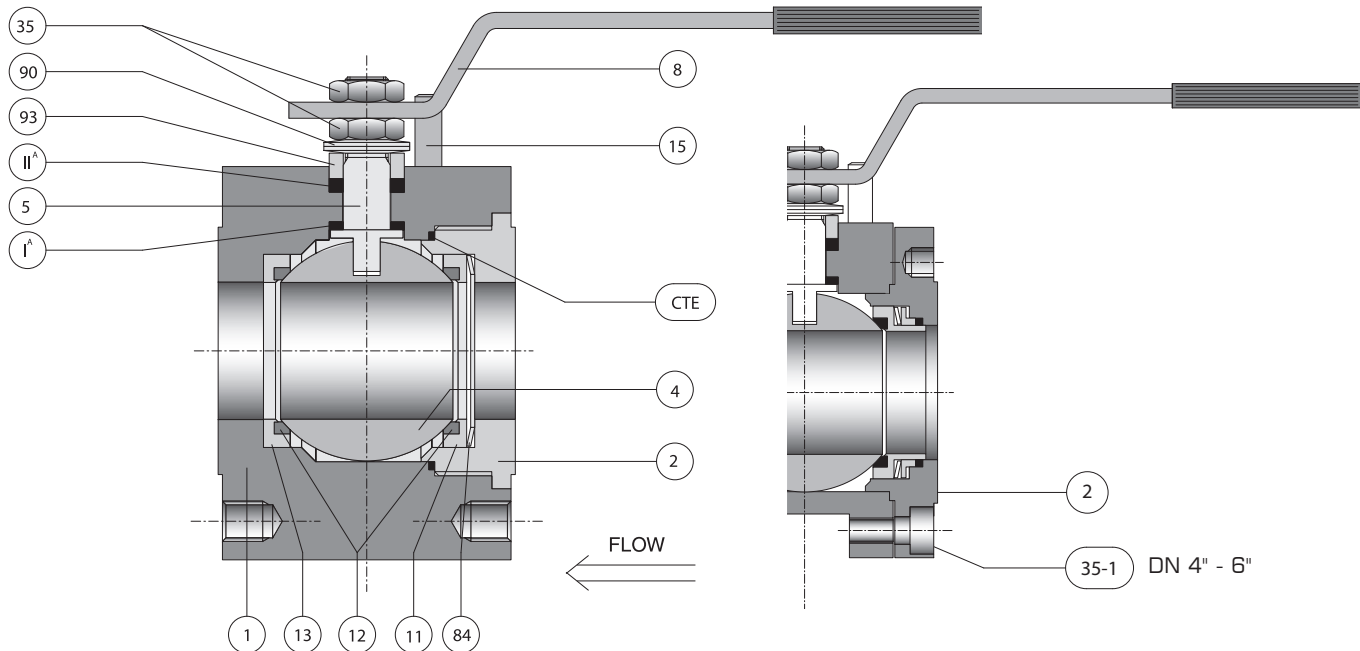

## Materiali base - base materials

CTE	Guarn. Corpo/Terminale	Body connector gasket	Grafoil	Grafoil	Grafoil
II <sup>A</sup>	Guarnizione Secondaria	Secondary Stem seal	Grafoil	Grafoil	Grafoil
I <sup>A</sup>	Guarnizione Primaria	Primary stem seal	Grafoil	Grafoil	Grafoil
93	Premi Baderna	Gland	304SS	304SS	304SS
90	Molle Stelo	Stem spring	UNS S30100	UNS S30100	UNS S30100
84	Molle Seggio	Seat spring	UNS S30100	UNS S30100	UNS S30100
80	Leva	Handle	Fe37 UNI 7070	Fe37 UNI 7070	Fe37 UNI 7070
35-1	Bulloneria Corpo/Terminale	Body/Connector Bolts	304 S.S.	304 S.S.	304 S.S.
35	Dadi Stelo	Nut	304 S.S.	304 S.S.	304 S.S.
15	Fermo Leva	Lever stopper	UNI 3740 Gr. 8.8	UNI 3740 Gr. 8.8	UNI 3740 Gr. 8.8
13	Cassetto Corpo	Body seat holder	A479 Tp.316	A479 Tp.316	A479 Tp.316
12	Seggio	Seat	PENTAFITE ST6 WC/CRC	PENTAFITE ST6 WC/CRC	PENTAFITE ST6 WC/CRC
11	Cassetto Terminale	Connector seat holder	A479 Tp.316	A479 Tp.316	A479 Tp.316.
5	Stelo	Stem	13% Cr. A564 Tp. 630	A564 Tp. 630 (17/4PH)	A564 Tp. 630 (17/4PH)
Riporto Sfera		Ball coating	HTC/HCR ST6 WC/CRC	HTC/HCR ST6 WC/CRC	HTC/HCR ST6 WC/CRC
4	Sfera	Ball	316 S.S.	Tp. 316 S.S.	316 S.S.
2	Terminale	Connector	A105	A479 Tp.304	A479 Tp.316/A351 CF8M
1	Corpo	Body	A105/A216 WCB	A479 Tp.304/A351 CF8	A479 Tp.316/A351 CF8M

P. No. Parte - Part Name

Materiale - Material

Altri materiali disponibili su richiesta - Other materials are available on request

HTC = Nitruri di Titanio (Titanium Nitrides); HCR = Nitruri di Cromo (Chrome Nitrides); ST6 = Stellite 6 Detonation Gun/HVOF  
WC = Carburi di Tungsteno (Tungsten Carbides Detonation Gun/HVOF); CRC = Carburi di Cromo (Chrome Carbides Detonation Gun/HVOF)





Dimensionamento <i>Design</i>	ASME B16.34 / EN 12569 / API 608 / EN 17292 ASME VIII DIV.1 / EN 12516-1
Estremità flangiate <i>Flanged ends</i>	ASME B16.5 Cl. 150 / 300 EN 1092-1 PN 10/16/25/40 DIN 2632 / 2633 / 2634 / 2635
Collaudo <i>Testing</i>	ASME B16.104 API 598 EN 12266-I ISO 5208 BS 6755-1

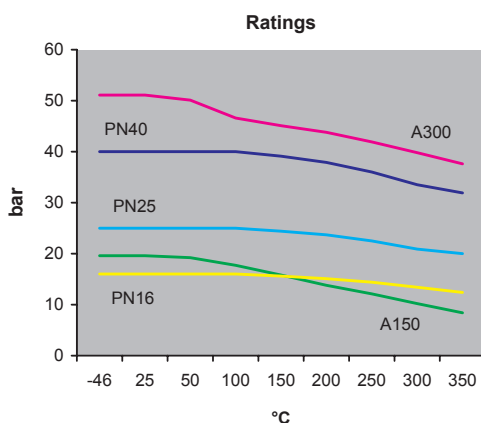
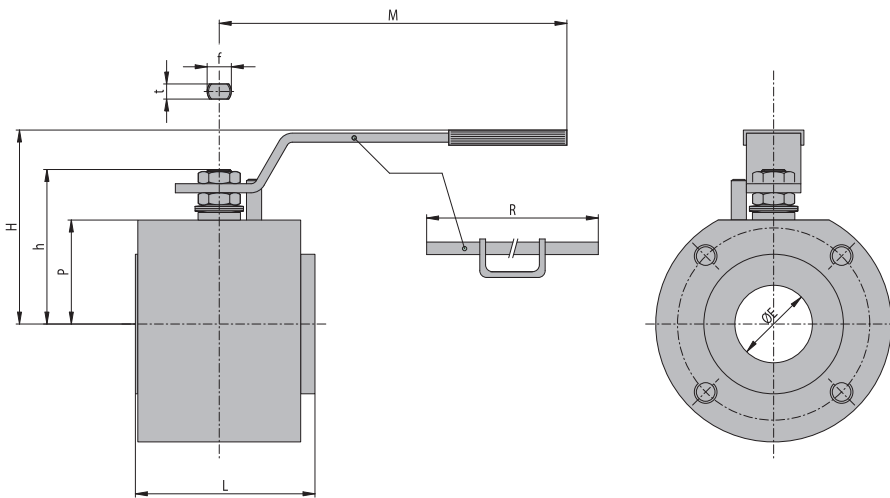
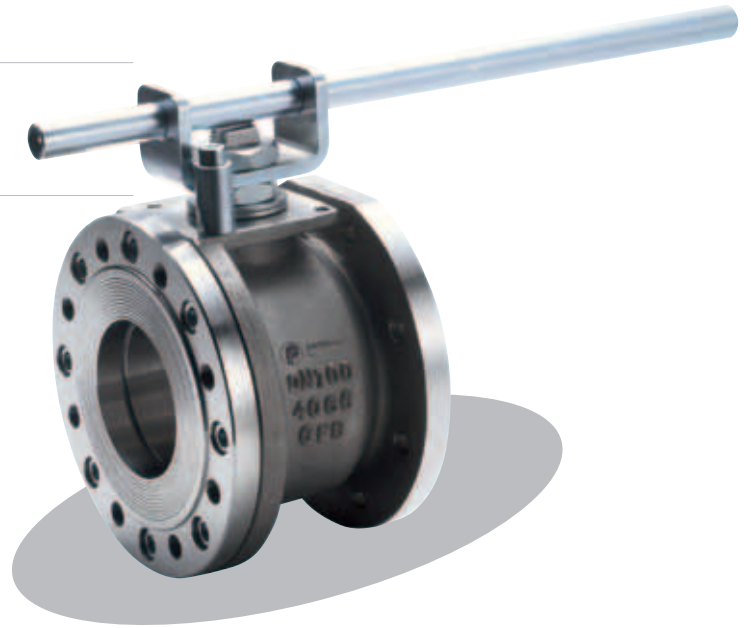

### Dimensioni - outline dimensions

DN	15	20	25	32	40	50	65	80	100	150
Ø"	1/2"	3/4"	1"	1 1/4"	1 1/2"	2"	2 1/2"	3"	4"	6"
ØE	14	19	24	29	38	48	64	76	95	152
L	45	50	56	60	75	91	120	127	152	243/255*
M	145	145	180	180	275	275	380	380	440	— <sup>(1)</sup>
R	—	—	—	—	—	—	—	—	500	800
H	64	66	85	90	118	126	139	144	200	265
h	52	55	70	73	96	101	122	128	157	220
P	33	36	43	48	63	68.5	82	88.5	111	145
F/t	10/6	10/6	12/8	12/8	16/10	16/10	22/14	22/14	30/18	45/30
Kg	1.5	2	2.7	4	6.5	9	16	20.5	42	80
ISO5211	F03	F03	F03	F03	F05	F05	F07	F07	F10	F14

\* PN25-40/ASME 300 RF

<sup>(1)</sup> È raccomandato riduttore manuale - *Manual gear recommended*

# VALVOLE A SFERA FLOTTANTE A SEGGI METALLICI

## METAL SEATED FLOATING BALL VALVES



BI-DIRECTIONAL

-46 °C +400 °C

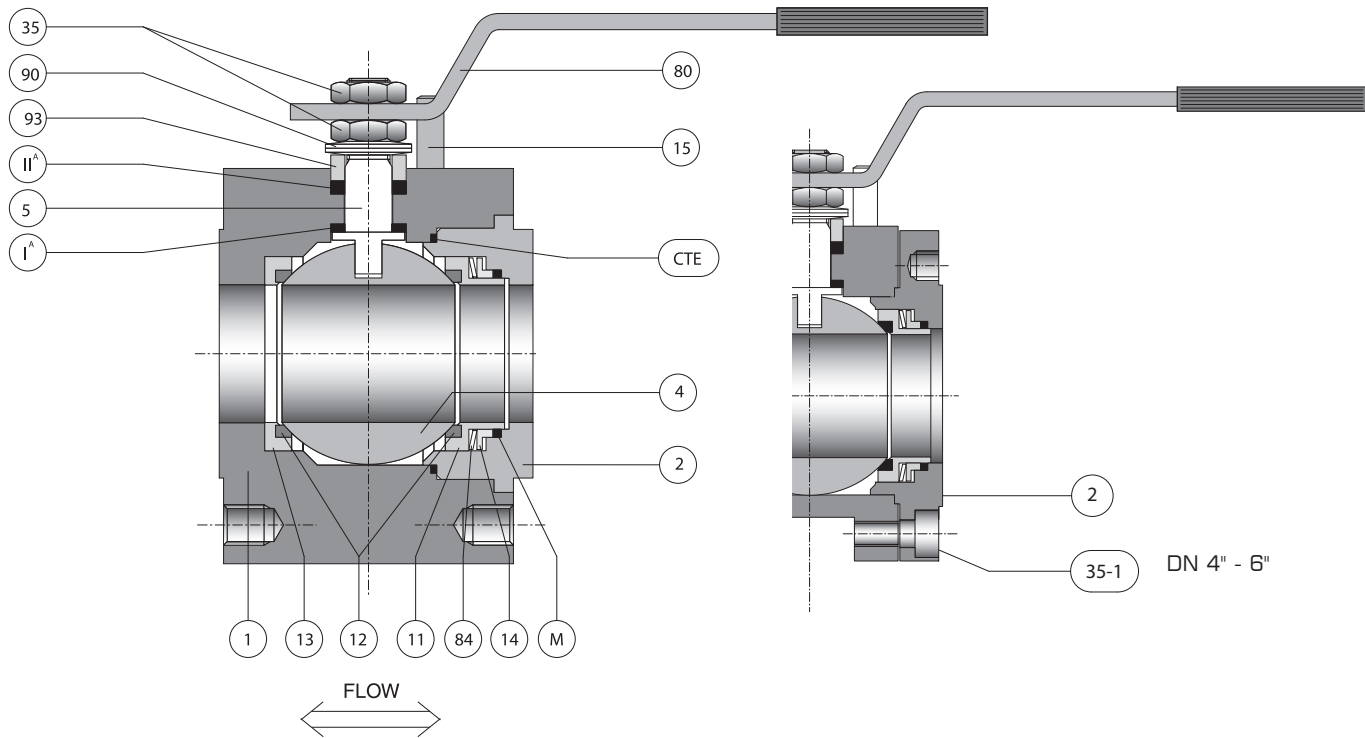

### Materiali base - base materials

CTE	Guarn. Corpo/Terminale	Body connector gasket	Grafoil	Grafoil	Grafoil
M	Guarn. Retroseggio	Backseat gasket	Grafoil	Grafoil	Grafoil
II <sup>A</sup>	Guarnizione Secondaria	Secondary Stem seal	Grafoil	Grafoil	Grafoil
I <sup>A</sup>	Guarnizione Primaria	Primary stem seal	Grafoil	Grafoil	Grafoil
93	Premi Baderna	Gland	304SS	304SS	304SS
90	Molle Stelo	Stem spring	UNS S30100	UNS S30100	UNS S30100
84	Molle Seggio	Seat spring	UNS S30100	UNS S30100	UNS S30100
80	Leva	Handle	Fe37 UNI 7070	Fe37 UNI 7070	Fe37 UNI 7070
35-1	Bulloneria Corpo/Terminale	Body/Connector Bolts	304 S.S.	304 S.S.	304 S.S.
35	Dadi Stelo	Nut	304 S.S.	304 S.S.	304 S.S.
15	Fermo Leva	Lever stopper	UNI 3740 Gr. 8.8	UNI 3740 Gr. 8.8	UNI 3740 Gr. 8.8
14	Premigrafoil	Compression ring	A479 Tp.316	A479 Tp.316	A479 Tp.316
13	Cassetto Corpo	Body seat holder	A479 Tp.316	A479 Tp.316	A479 Tp.316
12	Seggio	Seat	PENTAFITE ST6 WC/CRC	PENTAFITE ST6 WC/CRC	PENTAFITE ST6 WC/CRC
11	Cassetto Terminale	Connector seat holder	A479 Tp.316	A479 Tp.316	A479 Tp.316.
5	Stelo	Stem	13% Cr. A564 Tp.630 (17/4PH)	A564 Tp.630 (17/4PH)	A564 Tp.630 (17/4PH)
-	Riporto Sfera	Ball coating	HTC/HCR ST6 WC/CRC	HTC/HCR ST6 WC/CRC	HTC/HCR ST6 WC/CRC
4	Sfera	Ball	316 S.S.	316 S.S.	316 S.S.
2	Terminale	Connector	A105	A479 Tp.304	A479 Tp.316/A351 CF8M
1	Corpo	Body	A105/A216 WCB	A479 Tp.304/A351 CF8	A479 Tp.316/A351 CF8M

P. No. Parte - Part Name

Materiale - Material

Altri materiali disponibili su richiesta - Other materials are available on request



# AP10HP

BI-DIREZIONALI

Dimensionamento <i>Design</i>	ASME B16.34 / EN 12569 / API 608 / EN 17292 ASME VIII DIV.1 / EN 12516-1
Estremità flangiate <i>Flanged ends</i>	ASME B16.5 CL.600 / 900 EN 1092-1 PN 100 DIN 2637 (PN 100) / DIN 2638 (PN 160)
Collaudo <i>Testing</i>	ASME B16.104 API 598 EN 12266-I ISO 5208 BS 6755-I

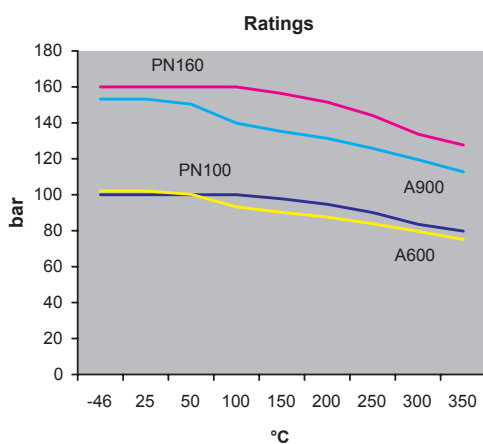
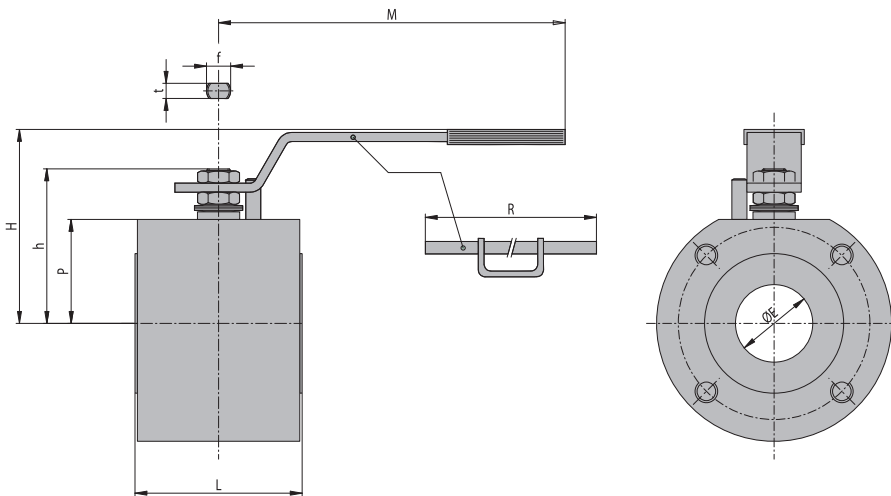
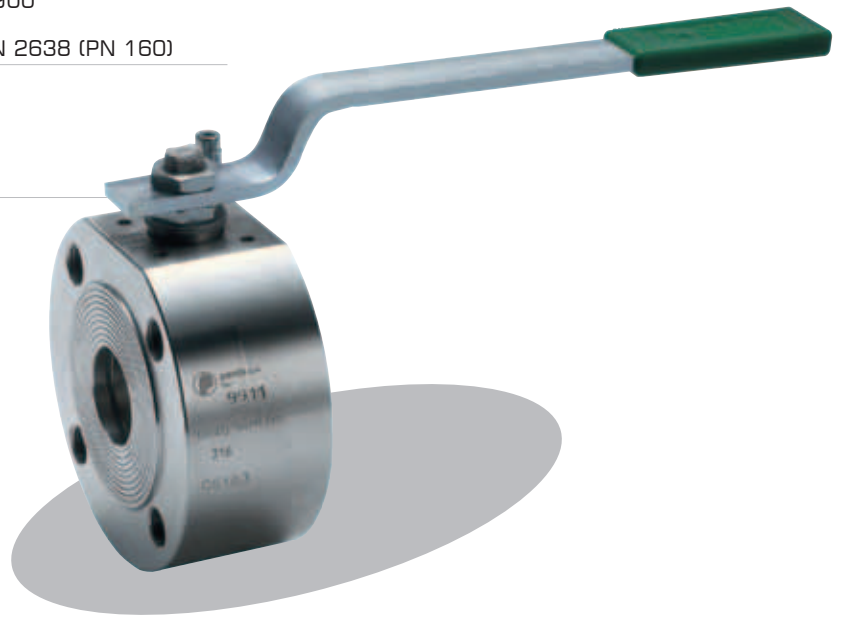

Dimensioni - *outline dimensions*

DN	15	20	25	32	40	50	65	80
Ø"	1/2"	3/4"	1"	1 1/4"	1 1/2"	2"	2 1/2"	3"
ØE	14	19	24	29	38	48	64	76
L	55	60/75*65/74*	75	85/100*	100	125	150	
M	145	145	275	275	380	380	440	440
R	—	—	—	—	—	—	500	500
H	65	68	105	115	127	135	160	180
h	53	55/70*	15	73	105	110	122	142
P	33	36/46*	51	53	65	15	93	98
F/t	10/6	10/6	16/10	16/10	22/14	22/14	30/18	30/18
Kg	2.5	3.5	4.8	6.5	10	13.5	25	40
ISO5211	F03	F03	F05	F05	F07	F07	F10	F10

\* PN 160/900RF

# VALVOLE A SFERA FLOTTANTE A SEGGI METALLICI

## METAL SEATED FLOATING BALL VALVES



BI-DIRECTIONAL

-46 °C +400 °C

AP

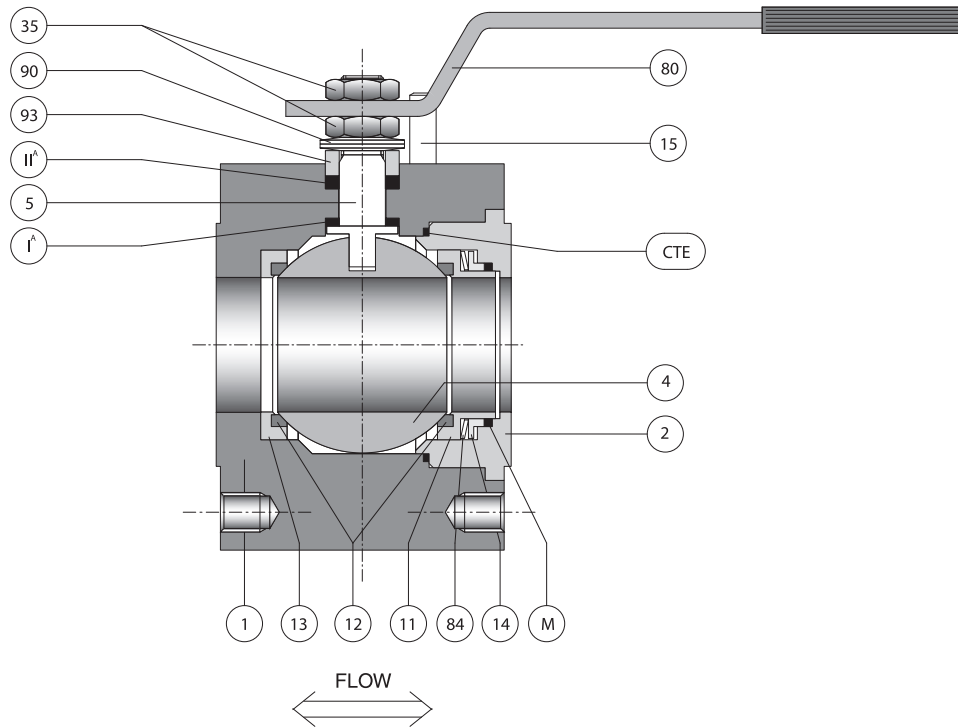

### Materiali base - base materials

CTE	Guarn. Corpo/Terminale	<i>Body connector gasket</i>	Grafoil	Grafoil	Grafoil
M	Guarn. Retroseggio	<i>Backseat gasket</i>	Grafoil	Grafoil	Grafoil
II <sup>A</sup>	Guarnizione Secondaria	<i>Secondary Stem seal</i>	Grafoil	Grafoil	Grafoil
I <sup>A</sup>	Guarnizione Primaria	<i>Primary stem seal</i>	Grafoil	Grafoil	Grafoil
93	Premi Baderna	<i>Gland</i>	304 S.S.	304 S.S.	304 S.S.
90	Molle Stelo	<i>Stem spring</i>	UNS S30100	UNS S30100	UNS S30100
84	Molle Seggio	<i>Seat spring</i>	UNS S30100	UNS S30100	UNS S30100
80	Leva	<i>Handle</i>	Fe37 UNI 7070	Fe37 UNI 7070	Fe37 UNI 7070
35	Dadi Stelo	<i>Nut</i>	304 S.S.	304 S.S.	304 S.S.
15	Fermo Leva	<i>Lever stopper</i>	UNI 3740 Gr. 8.8	UNI 3740 Gr. 8.8	UNI 3740 Gr. 8.8
14	Premigrafoil	<i>Compression ring</i>	A479 Tp.316	A479 Tp.316	A479 Tp.316
13	Cassetto Corpo	<i>Body seat holder</i>	A479 Tp.316	A479 Tp.316	A479 Tp.316
12	Seggio	<i>Seat</i>	PENTAFITE ST6 WC/CRC	PENTAFITE ST6 WC/CRC	PENTAFITE ST6 WC/CRC
11	Cassetto Terminale	<i>Connector seat holder</i>	A479 Tp.316	A479 Tp.316	A479 Tp.316
5	Stelo	<i>Stem</i>	13%Cr. A564 Tp.630	A564 Tp.630 (17/4PH)	A564 Tp.630 (17/4PH)
-	Riporto Sfera	<i>Ball coating</i>	HTC/HCR ST6 WC/CRC	HTC/HCR ST6 WC/CRC	HTC/HCR ST6 WC/CRC
4	Sfera	<i>Ball</i>	316 S.S.	316 S.S.	316 S.S.
2	Terminale	<i>Connector</i>	A105	A479 Tp.304	A479 Tp.316/A351 CF8M
1	Corpo	<i>Body</i>	A105/A216 WCB	A479 Tp.304/A351 CF8	A479 Tp.316/A351 CF8M

P. No. Parte - Part Name

Materiale - Material

Altri materiali disponibili su richiesta - Other materials are available on request



Dimensionamenti - valvola <i>Design - valve</i>	ASME B16.34 / EN 12569 / API 608 / EN 17292 ASME VIII DIV.1 / EN 12516-1
Dimensionamenti - camicia <i>Design - jacket</i>	ASME VIII DIV.1
Estremità flangiate <i>Flanged ends</i>	ASME B16.5 CL. 150 / 300 / 600 EN 1092-1 PN 10/16/25/40/100
Attacchi camicia <i>Jacket connections</i>	SW / NPT CL. 150 RF PN 10/16
Collaudo <i>Testing</i>	ASME B16.104 API 598 EN 12266-1 ISO 5208 BS 6755-1

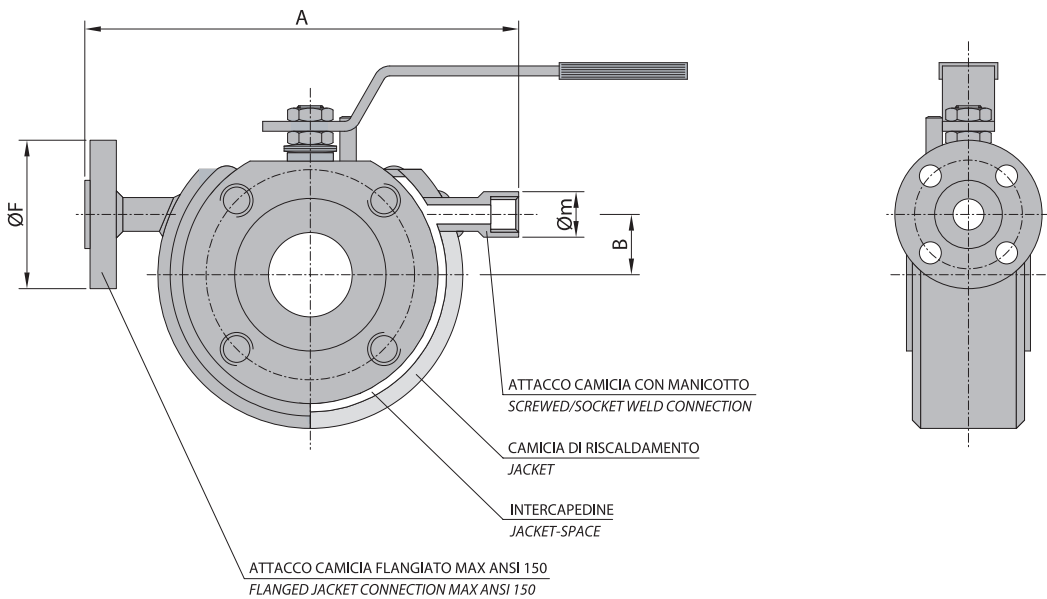

Dimensioni - outline dimensions									
DN	15	20	25	40	50	65	80	100	150
Ø"	1/2"	3/4"	1"	1 1/2"	2"	2 1/2"	3"	4"	6"
A	160	160	190	230	250	270	300	340	420
B	0	0	0	30	30	45	50	70	95
ØF	DN 15							DN 25	
Øm	Ø 1/2"							Ø 1"	
Kg	3	3.5	4.5	9	11	20	25	40	80

# VALVOLE A SFERA FLOTTANTE A SEGGI METALLICI INCAMICIATA

## METAL SEATED FLOATING BALL VALVES C/W JACKET



-46 °C +400 °C

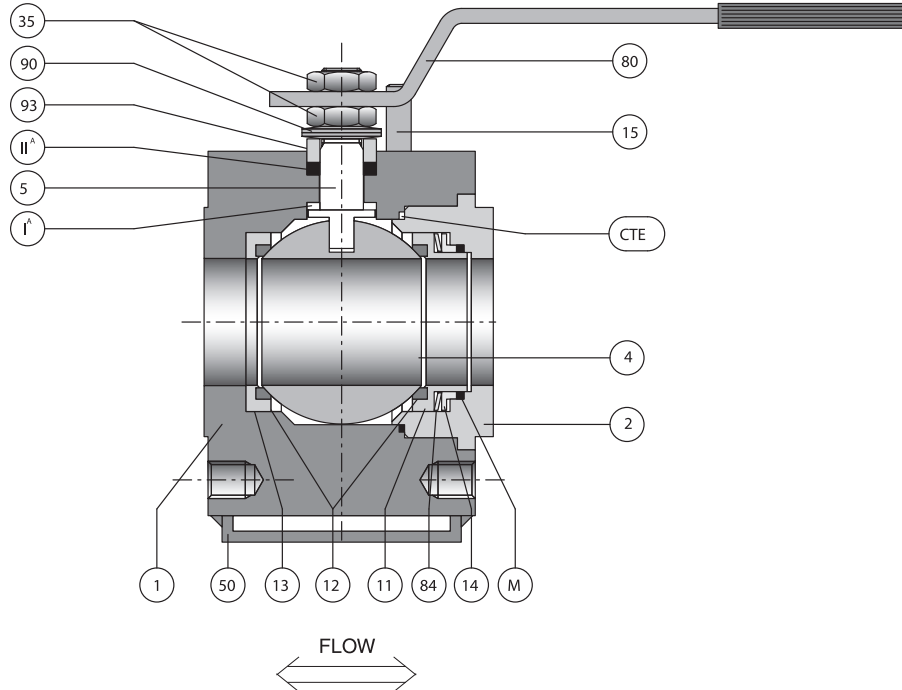

### Materiali base - base materials

CTE	Guarn. Corpo/Terminale	Body connector gasket	Grafoil	Grafoil	Grafoil
M	Guarn. Retroseggio	Backseat gasket	Grafoil	Grafoil	Grafoil
II <sup>A</sup>	Guarnizione Secondaria	Secondary Stem seal	Grafoil	Grafoil	Grafoil
I <sup>A</sup>	Guarnizione Primaria	Primary stem seal	Grafoil	Grafoil	Grafoil
93	Premi Baderna	Gland	304 S.S.	304 S.S.	304 S.S.
90	Molle Stelo	Stem spring	UNS S30100	UNS S30100	UNS S30100
84	Molle Seggio	Seat spring	UNS S30100	UNS S30100	UNS S30100
80	Leva	Handle	Fe37 UNI 7070	Fe37 UNI 7070	Fe37 UNI 7070
50	Camicia riscaldamento	Heating jacket	A105	304 S.S.	304 S.S.
35	Dadi Stelo	Nut	304 S.S.	304 S.S.	304 S.S.
15	Fermo Leva	Lever stopper	UNI 3740 Gr. 8.8	UNI 3740 Gr. 8.8	UNI 3740 Gr. 8.8
14	Premigrafoil	Compression ring	A479 Tp.316	A479 Tp.316	A479 Tp.316
13	Cassetto Corpo	Body seat holder	A479 Tp.316	A479 Tp.316	A479 Tp.316
12	Seggio	Seat	PENTAFITE ST6 WC/CRC	PENTAFITE ST6 WC/CRC	PENTAFITE ST6 WC/CRC
11	Cassetto Terminale	Connector seat holder	A479 Tp.316	A479 Tp.316	A479 Tp.316.
5	Stelo	Stem	13% Cr. A564 Tp.630 (17/4PH)	A564 Tp.630 (17/4PH)	A564 Tp.630 (17/4PH)
-	Riporto Sfera	Ball coating	HTC/HCR ST6 WC/CRC	HTC/HCR ST6 WC/CRC	HTC/HCR ST6 WC/CRC
4	Sfera	Ball	A479 Tp.316	A479 Tp.316	A479 Tp.316
2	Terminale	Connector	A105	A479 Tp.304	A479 Tp.316
1	Corpo	Body	A105	A479 Tp.304	A479 Tp.316

P. No. Parte - Part Name

Materiale - Material

Altri materiali disponibili su richiesta - Other materials are available on request





# AP20P

## BI-DIREZIONALE

Dimensionamenti <i>Design</i>	ASME B16.34 / EN 17292 / API 608 ASME VIII DIV.1 / EN 12516-1
Estremità <i>Ends</i>	NPT ASME B 1.20.1 SW ASME B 16.11 BW ASME B 16.25 (con nippli integrali - <i>c/n integral nipples</i> )
Collaudo <i>Testing</i>	ASME B16.104 API 598 EN 12266-I ISO 5208 BS 6755-I

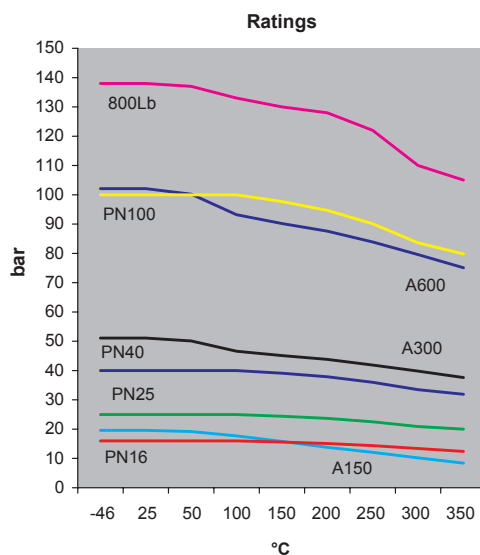
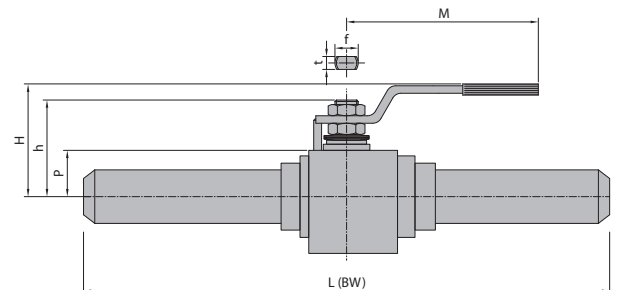
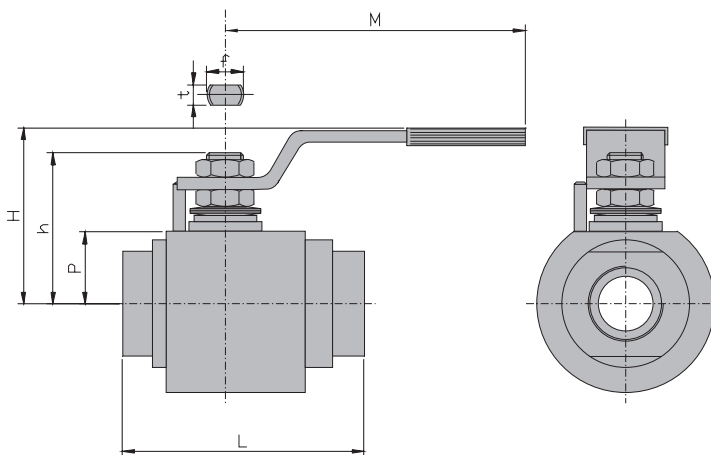

### Dimensioni - *outline dimensions*

DN	15	20	25	40	50
Ø"	1/2"	3/4"	1"	1 1/2"	2"
ØE	12.5	19	24	38	51
L(NPT)	80	90	110	130	155
L(SW)	70	85	105	125	140
L(BW)	270	285	305	325	350
ØD	58	64	78	104	138
M	145	145	275	380	380
H	70	75	83	123	120
h	50	53	63	91.5	102
P	24	27	32	42	61
F/t	10/6	10/6	16/10	22/14	22/14
Kg	1.2	1.5	2.5	5.3	11.5
ISO5211	F03	F03	F05	F07	F07

# VALVOLE A SFERA FLOTTANTE A SEGGI METALLICI

## METAL SEATED FLOATING BALL VALVES



BI-DIRECTIONAL

-46 °C +400 °C

AP

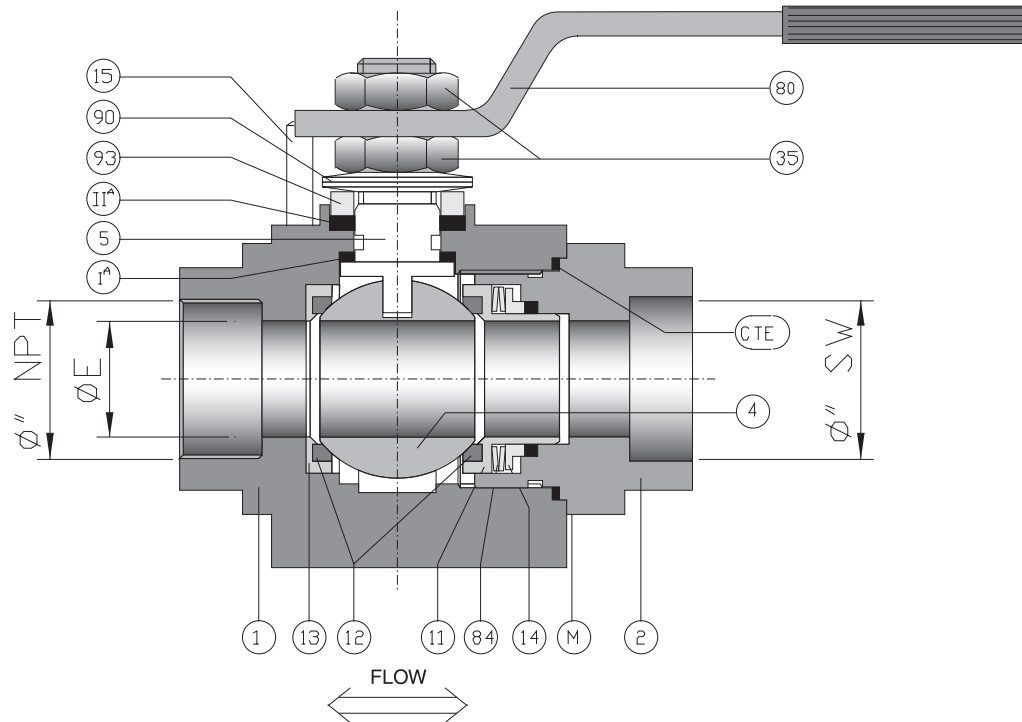

### Materiali base - base materials

CTE	Guarn. Corpo/Terminale	Body connector gasket	Grafoil	Grafoil
M	Guarn. Retroseggio	Backseat gasket	Grafoil	Grafoil
II <sup>A</sup>	Guarnizione Secondaria	Secondary Stem seal	Grafoil	Grafoil
I <sup>A</sup>	Guarnizione Primaria	Primary stem seal	Grafoil	Grafoil
93	Premi Baderna	Gland	304 S.S.	304 S.S.
90	Molle Stelo	Stem spring	UNS S30100	UNS S30100
84	Molle Seggio	Seat spring	UNS S30100	UNS S30100
80	Leva	Handle	Fe37 UNI 7070	Fe37 UNI 7070
35	Dadi Stelo	Nut	304 S.S.	304 S.S.
15	Fermo Leva	Lever stopper	Gr. 8.8 UNI 3740	Gr. 8.8 UNI 3740
14	Premigrafoil	Compression ring	A479 Tp.316	A479 Tp.316
13	Cassetto Corpo	Body seat holder	A479 Tp.316	A479 Tp.316
12	Seggio	Seat	PENTAFITE ST6 WC/CRC RPTFE/PEEK	PENTAFITE ST6 WC/CRC RPTFE/PEEK
11	Cassetto Terminale	Connector seat holder	A479 Tp.316	A479 Tp.316.
5	Stelo	Stem	A564 Tp.630 (17/4PH)	A564 Tp.630 (17/4PH)
-	Riporto Sfera	Ball coating	HTC/HCR ST6 WC/CRC	HTC/HCR ST6 WC/CRC
4	Sfera	Ball	A479 Tp.316	A479 Tp.316
2	Terminale	Connector	A105	A479 Tp.316
1	Corpo	Body	A105	A479 Tp.316

**P. No. Parte - Part Name**

**Materiale - Material**

**Altri materiali disponibili su richiesta - Other materials are available on request**



Dimensionamenti <i>Design</i>	ASME B16.34 / EN 12569 / API 608 / EN 17292 ASME VIII DIV.1 / EN 12516-1
Estremità flangiate <i>Flanged ends</i>	ASME B 16.5 CL.300 EN 1092-1 PN 25 / PN 40 DIN 2634 (PN 25) / 2635 (PN 40)
Estremità BW <i>BW ends</i>	ASME B 16.25
Collaudo <i>Testing</i>	ASME B16.104 API 598 EN 12266-I ISO 5208 BS 6755-I

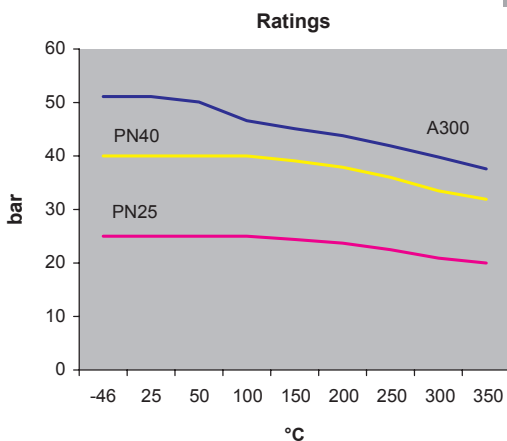
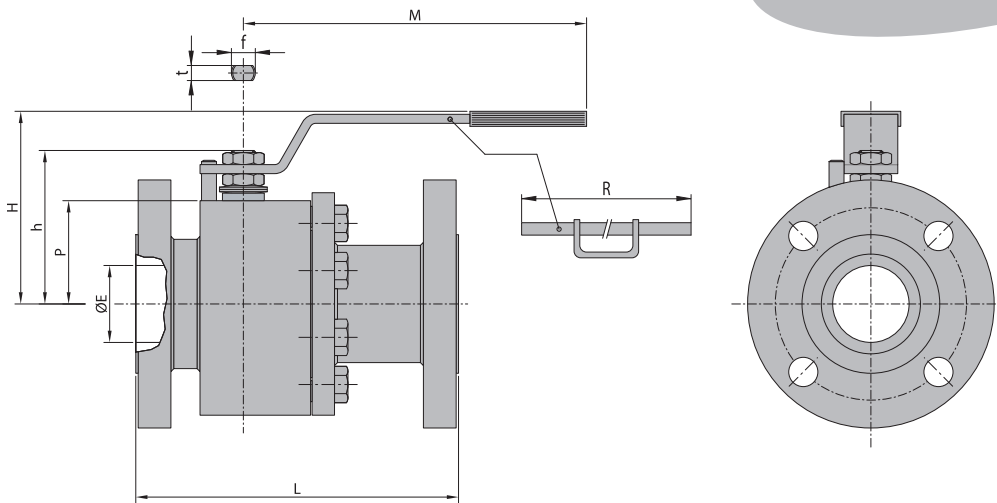

### Dimensioni - *outline dimensions*

DN	15	20	25	32	40	50	65	80	100	150
Ø"	1/2"	3/4"	1"	1 1/4"	1 1/2"	2"	2 1/2"	3"	4"	6"
ØE	14	19	24	29	38	51	65	76	102	152
L	140	152	165	178	191	216	241	283	305	403
M	145	145	180	180	275	275	380	380	440	— <sup>(1)</sup>
R	—	—	—	—	—	—	—	—	500	800
H	64	66	85	90	118	128	139	144	200	265
h	52	55	70	73	96	103	122	128	157	220
P	33	36	43	48	63	68.5	82	88.5	111	153
F/t	10/6	10/6	12/8	12/8	16/10	16/10	22/14	22/14	30/18	45/30
Kg	3	4	6	8	13.5	19	25	40	63	105
ISO5211	F03	F03	F03	F03	F05	F05	F07	F07	F10	F14

# VALVOLE A SFERA FLOTTANTE A SEGGI METALLICI

## METAL SEATED FLOATING BALL VALVES



AP

BI-DIRECTIONAL

-46 °C +400 °C

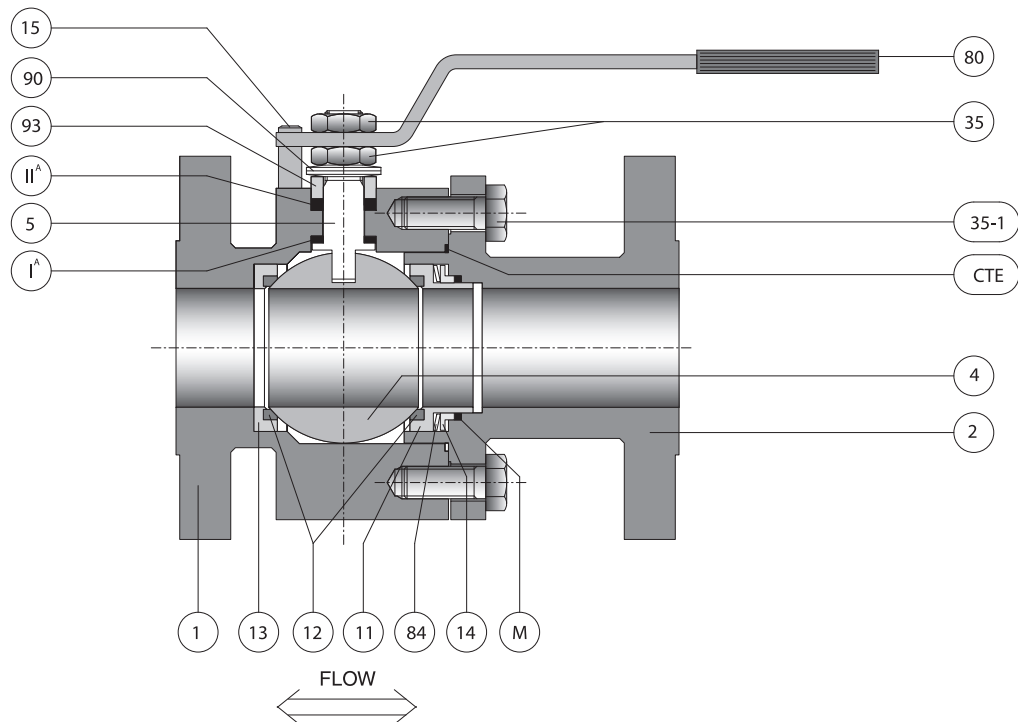

### Materiali base - base materials

CTE	Guarn. Corpo/Terminale	<i>Body connector gasket</i>	Grafoil	Grafoil	Grafoil
M	Guarn. Retroseggio	<i>Backseat gasket</i>	Grafoil	Grafoil	Grafoil
II <sup>A</sup>	Guarnizione Secondaria	<i>Secondary Stem seal</i>	Grafoil	Grafoil	Grafoil
I <sup>A</sup>	Guarnizione Primaria	<i>Primary stem seal</i>	Grafoil	Grafoil	Grafoil
93	Premi Baderna	<i>Gland</i>	304 S.S.	304 S.S.	304 S.S.
90	Molle Stelo	<i>Stem spring</i>	UNS S30100	UNS S30100	UNS S30100
84	Molle Seggio	<i>Seat spring</i>	UNS S30100	UNS S30100	UNS S30100
80	Leva	<i>Handle</i>	Fe37 UNI 7070	Fe37 UNI 7070	Fe37 UNI 7070
35-1	Bulloneria Corpo/Terminale	<i>Body/Connector Bolts</i>	A193 B7 A194 Gr.2H	A193 B8 A 194 Gr.8	A193 B8M A194 Gr.Gr.8M
35	Dadi Stelo	<i>Nut</i>	304 S.S.	304 S.S.	304 S.S.
15	Fermo Leva	<i>Lever stopper</i>	Gr. 8.8 UNI 3740	Gr. 8.8 UNI 3740	Gr. 8.8 UNI 3740
14	Premigrafoil	<i>Compression ring</i>	A479 Tp.316	A479 Tp.316	A479 Tp.316
13	Cassetto Corpo	<i>Body seat holder</i>	A479 Tp.316	A479 Tp.316	A479 Tp.316
12	Seggio	<i>Seat</i>	PENTAFITE ST6 WC/CRC RPTFE/PEEK	PENTAFITE ST6 WC/CRC RPTFE/PEEK	PENTAFITE ST6 WC/CRC RPTFE/PEEK
11	Cassetto Terminale	<i>Connector seat holder</i>	A479 Tp.316	A479 Tp.316	A479 Tp.316.
5	Stelo	<i>Stem</i>	13% Cr. A564 Tp.630 (17/4PH)	A564 Tp.630 (17/4PH)	A564 Tp.630 (17/4PH)
-	Riporto Sfera	<i>Ball coating</i>	HTC/HCR ST6 WC/CRC	HTC/HCR ST6 WC/CRC	HTC/HCR ST6 WC/CRC
4	Sfera	<i>Ball</i>	316 S.S. A351 CF8M	316 S.S. A351 CF8M	316 S.S. A351 CF8M
2	Terminale	<i>Connector</i>	A105 / A216 WCB	A479 Tp.304 / A351 CF8	A479Tp.316/A351 CF8M
1	Corpo	<i>Body</i>	A105 / A216 WCB	A479 Tp.304 / A351 CF8	A479 Tp.316 / A 351 CF8M

**P. No. Parte - Part Name**

**Materiale - Material**

**Altri materiali disponibili su richiesta – Other materials are available on request**

**Altre estremità disponibili su richiesta – Other end connections available on request**

HTC = Nitruri di Titanio (*Titanium Nitrides*); HCR = Nitruri di Cromo (*Chrome Nitrides*); ST6 = Stellite 6 *Detonation Gun/HVOF*

WC = Carburi di Tungsteno (*Tungsten Carbides Detonation Gun/HVOF*); CRC = Carburi di Cromo (*Chrome Carbides Detonation Gun/HVOF*)



Dimensionamenti <i>Design</i>	ASME B16.34 / EN 12569 / API 608 / EN 17292 ASME VIII DIV.1 / EN 12516-1
Estremità flangiate <i>Flanged ends</i>	ASME B 16.5 CL.150 EN 1092-1 PN 16 DIN 2633 PN 16
Collaudo <i>Testing</i>	ASME B16.104 API 598 EN 12266-I ISO 5208 BS 6755-I

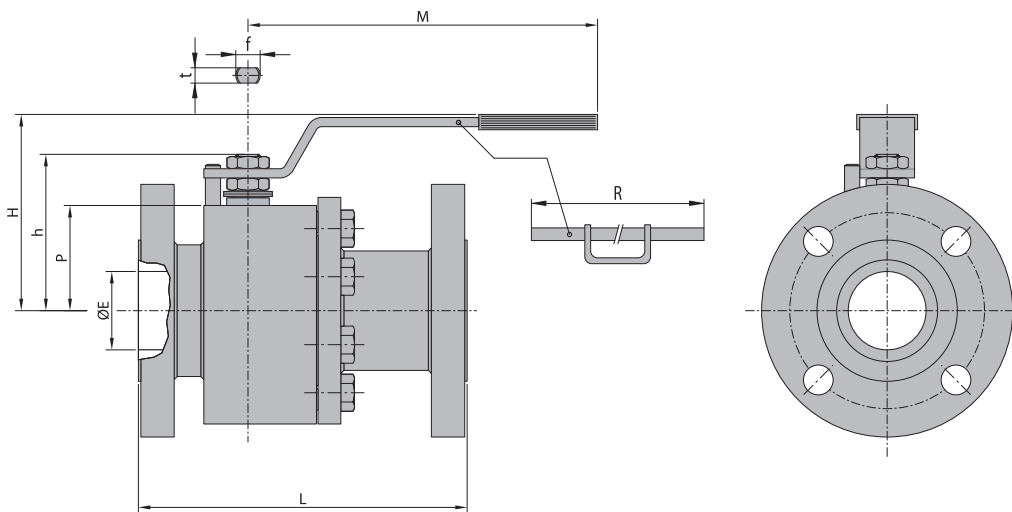
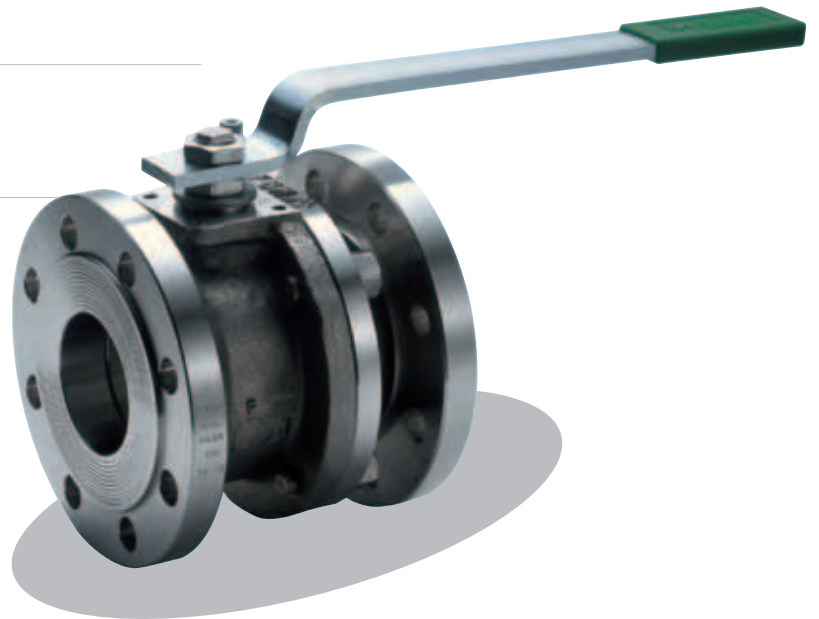

### Dimensioni - outline dimensions

DN	15	20	25	32	40	50	65	80	100	150
Ø"	1/2"	3/4"	1"	1 1/4"	1 1/2"	2"	2 1/2"	3"	4"	6"
ØE	14	19	24	29	38	51	64	76	102	152
L	108	117	127	140	165	178	190	203	229	394
M	145	145	180	180	275	275	380	380	440	— <sup>(1)</sup>
R	—	—	—	—	—	—	—	—	500	800
H	64	66	85	90	118	128	139	144	200	265
h	52	55	70	73	96	103	122	128	157	220
P	33	36	43	48	63	68.5	82	88.5	111	153
F/t	10/6	10/6	12/8	12/8	16/10	16/10	22/14	22/14	30/18	45/30
Kg	2.5	3	5.5	7	11	17	22	26	48	71
ISO5211	F03	F03	F03	F03	F05	F05	F07	F07	F10	F14

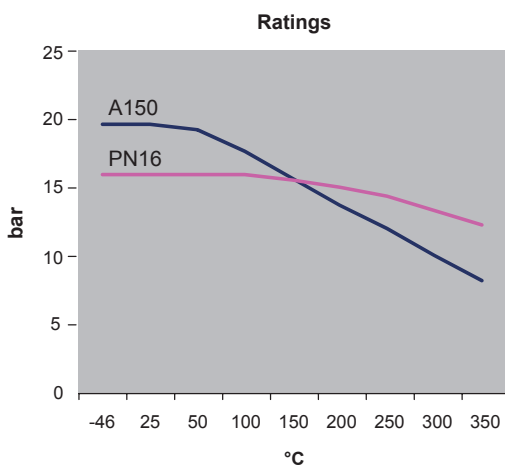

<sup>(1)</sup> È raccomandato riduttore manuale - *Manual gear recommended*

# VALVOLE A SFERA FLOTTANTE A SEGGI METALLICI

## METAL SEATED FLOATING BALL VALVES



AP

BI-DIRECTIONAL

-46 °C +400 °C

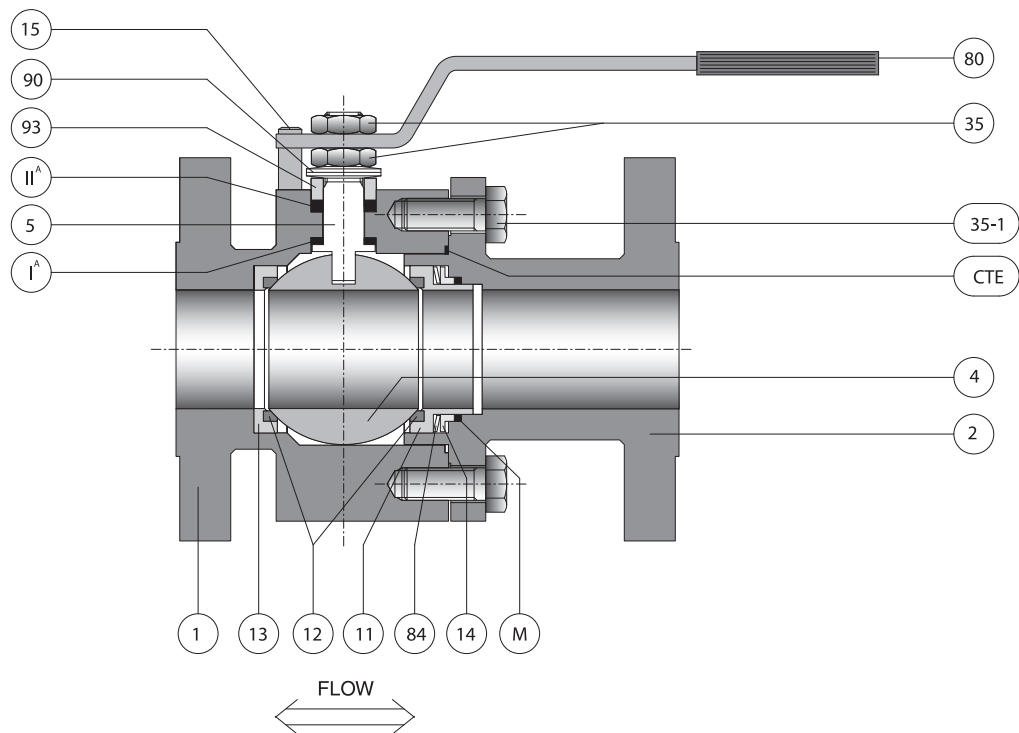

### Materiali base - base materials

CTE	Guarn. Corpo/Terminale	<i>Body connector gasket</i>	Grafoil	Grafoil	Grafoil
M	Guarn. Retroseggio	<i>Backseat gasket</i>	Grafoil	Grafoil	Grafoil
II <sup>A</sup>	Guarnizione Secondaria	<i>Secondary Stem seal</i>	Grafoil	Grafoil	Grafoil
I <sup>A</sup>	Guarnizione Primaria	<i>Primary stem seal</i>	Grafoil	Grafoil	Grafoil
93	Premi Baderna	<i>Gland</i>	304 S.S.	304 S.S.	304 S.S.
90	Molle Stelo	<i>Stem spring</i>	UNS S30100	UNS S30100	UNS S30100
84	Molle Seggio	<i>Seat spring</i>	UNS S30100	UNS S30100	UNS S30100
80	Leva	<i>Handle</i>	Fe37 UNI 7070	Fe37 UNI 7070	Fe37 UNI 7070
35-1	Bulloneria Corpo/Terminale	<i>Body/Connector Bolts</i>	A193 B7 A194 Gr.2H	A193 B8 A 194 Gr.8	A193 B8M A194 Gr.Gr.8M
35	Dadi Stelo	<i>Nut</i>	304 S.S.	304 S.S.	304 S.S.
15	Fermo Leva	<i>Lever stopper</i>	Gr. 8.8 UNI 3740	Gr. 8.8 UNI 3740	Gr. 8.8 UNI 3740
14	Premigrafoil	<i>Compression ring</i>	A479 Tp.316	A479 Tp.316	A479 Tp.316
13	Cassetto Corpo	<i>Body seat holder</i>	A479 Tp.316	A479 Tp.316	A479 Tp.316
12	Seggio	<i>Seat</i>	PENTAFITE ST6 WC/CRC RPTFE/PEEK	PENTAFITE ST6 WC/CRC RPTFE/PEEK	PENTAFITE ST6 WC/CRC RPTFE/PEEK
11	Cassetto Terminale	<i>Connector seat holder</i>	A479 Tp.316	A479 Tp.316	A479 Tp.316.
5	Stelo	<i>Stem</i>	13% Cr. A564 Tp.630 (17/4PH)	A564 Tp.630 (17/4PH)	A564 Tp.630 (17/4PH)
-	Riporto Sfera	<i>Ball coating</i>	HTC/HCR ST6 WC/CRC	HTC/HCR ST6 WC/CRC	HTC/HCR ST6 WC/CRC
4	Sfera	<i>Ball</i>	316 S.S. A351 CF8M	316 S.S. A351 CF8M	316 S.S. A351 CF8M
2	Terminale	<i>Connector</i>	A105/A216 WCB	A479 Tp.304/A351 CF8	A479 Tp.316/A351 CF8M
1	Corpo	<i>Body</i>	A105/A216 WCB	A479 Tp.304/A351 CF8	A479 Tp.316/A351 CF8M

**P. No. Parte - Part Name**

**Materiale - Material**

**Altri materiali disponibili su richiesta - Other materials are available on request**

**Altre estremità disponibili su richiesta - Other end connections available on request**

HTC = Nitruri di Titanio (*Titanium Nitrides*); HCR = Nitruri di Cromo (*Chrome Nitrides*); ST6 = Stellite 6 *Detonation Gun/HVOF*  
WC = Carburi di Tungsteno (*Tungsten Carbides Detonation Gun/HVOF*); CRC = Carburi di Cromo (*Chrome Carbides Detonation Gun/HVOF*)





# AP68

## BIDIREZIONALE

Dimensionamenti <i>Design</i>	EN 12569 / EN 17292 ASME VIII DIV.1 / EN 12516-1
Estremità flangiate <i>Flanged ends</i>	EN 1092-1 PN 16/PN40 DIN 2633 PN 16/2634 (PN40)
Collaudo <i>Testing</i>	ASME B16.104 API 598 EN 12266-I ISO 5208 BS 6755-I

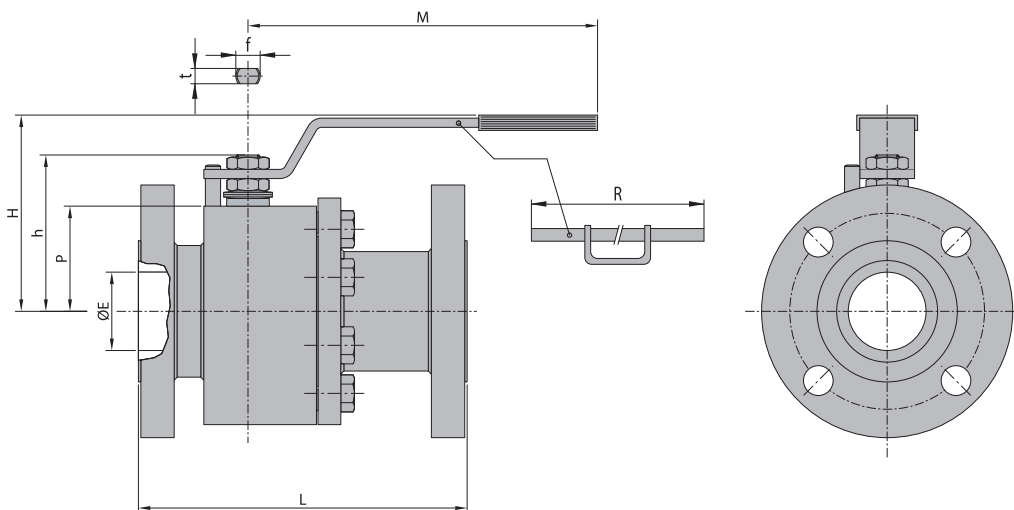
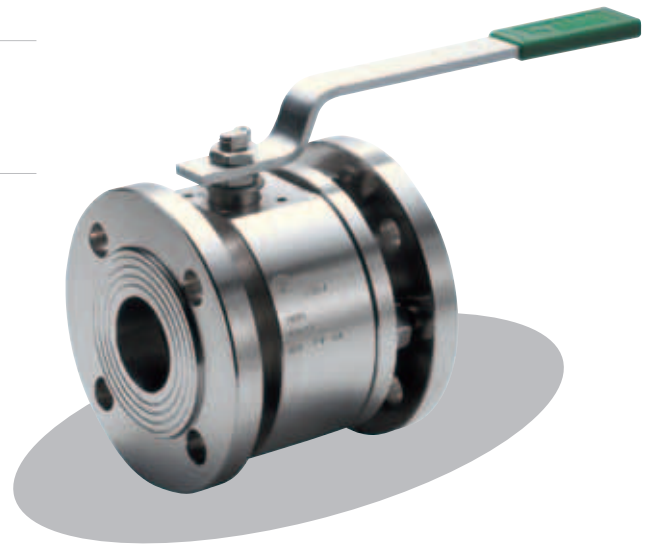

### Dimensioni - outline dimensions

DN	15	20	25	32	40	50	65	80	100	150
Ø"	1/2"	3/4"	1"	1 1/4"	1 1/2"	2"	2 1/2"	3"	4"	6"
PN	PN40								PN16	
ØE	14	19	24	29	38	51	65	76	102	152
L	115	120	125	130	140	150	170	180	190	350
DIN3202	F4	F4	F4	F4	F4	F4	F4	F4	F4	F5
M	145	145	180	180	275	275	380	380	440	— <sup>(1)</sup>
R	—	—	—	—	—	—	—	—	500	800
H	64	66	85	90	118	128	139	144	200	265
h	52	55	70	73	96	103	122	128	157	220
P	33	36	43	48	63	68.5	82	88.5	111	153
F/t	10/6	10/6	12/8	12/8	16/10	16/10	22/14	22/14	30/18	45/30
Kg	2.7	3	5.5	6.8	10.5	15.5	21	25	38	70
ISO5211	F03	F03	F03	F03	F05	F05	F07	F07	F10	F14

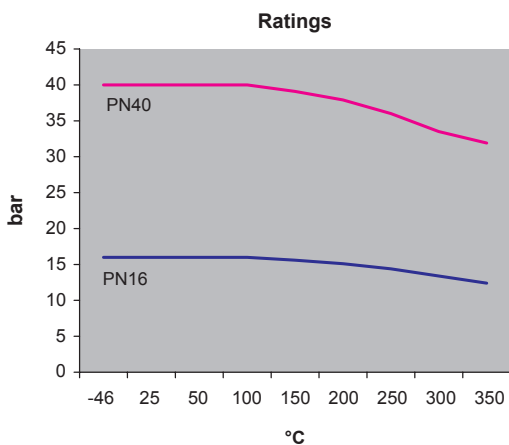

<sup>(1)</sup> È raccomandato riduttore manuale - *Manual gear recommended*

# VALVOLE A SFERA FLOTTANTE A SEGGI METALLICI

## METAL SEATED FLOATING BALL VALVES



AP

BI-DIRECTIONAL

-46 °C +400 °C

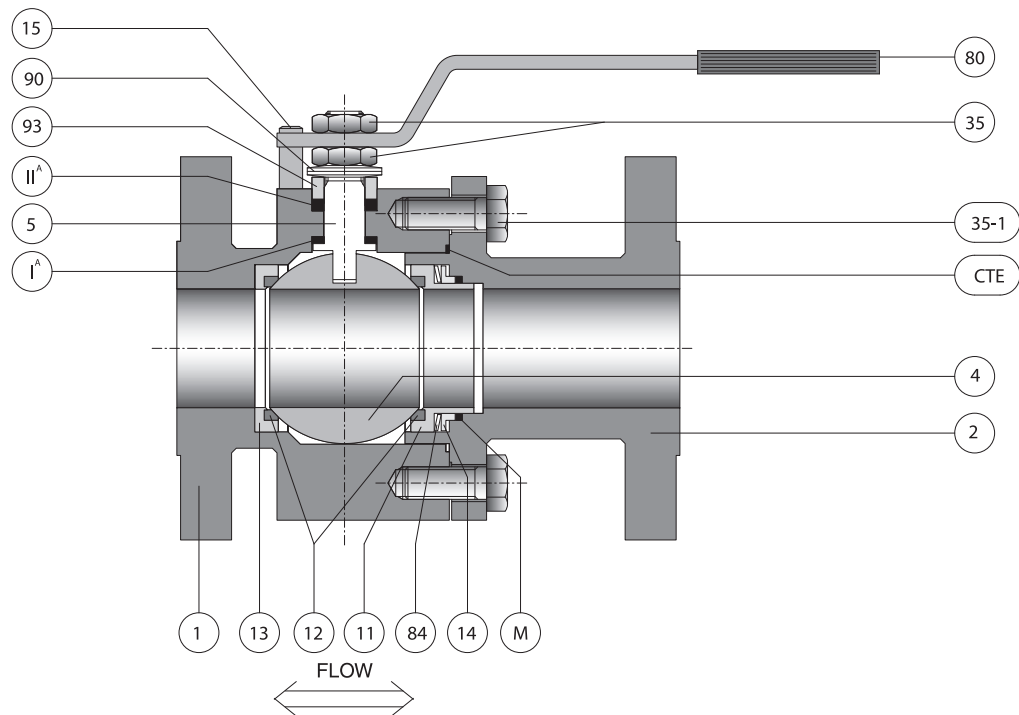

### Materiali base - base materials

CTE	Guarn. Corpo/Terminale	Body connector gasket	Grafoil	Grafoil	Grafoil
M	Guarn. Retroseggio	Backseat gasket	Grafoil	Grafoil	Grafoil
IIA	Guarnizione Secondaria	Secondary Stem seal	Grafoil	Grafoil	Grafoil
IA	Guarnizione Primaria	Primary stem seal	Grafoil	Grafoil	Grafoil
93	Premi Baderna	Gland	304 S.S.	304 S.S.	304 S.S.
90	Molle Stelo	Stem spring	UNS S30100	UNS S30100	UNS S30100
84	Molle Seggio	Seat spring	UNS S30100	UNS S30100	UNS S30100
80	Leva	Handle	Fe37 UNI 7070	Fe37 UNI 7070	Fe37 UNI 7070
35-1	Bulloneria Corpo/Terminale	Body/Connector Bolts	A193 B7 A194 Gr.2H	A193 B8 A 194 Gr.8	A193 B8M A194 Gr.Gr.8M
35	Dadi Stelo	Nut	304 S.S.	304 S.S.	304 S.S.
15	Fermo Leva	Lever stopper	Gr. 8.8 UNI 3740	Gr. 8.8 UNI 3740	Gr. 8.8 UNI 3740
14	Premigrafoil	Compression ring	A479 Tp.316	A479 Tp.316	A479 Tp.316
13	Cassetto Corpo	Body seat holder	A479 Tp.316	A479 Tp.316	A479 Tp.316
12	Seggio	Seat	PENTAFITE ST6 WC/CRC	PENTAFITE ST6 WC/CRC	PENTAFITE ST6 WC/CRC
11	Cassetto Terminale	Connector seat holder	A479 Tp.316	A479 Tp.316	A479 Tp.316.
5	Stelo	Stem	13% Cr. A564 Tp.630 (17/4PH)	A564 Tp.630 (17/4PH)	A564 Tp.630 (17/4PH)
-	Riporto Sfera	Ball coating	HTC/HCR ST6 WC/CRC	HTC/HCR ST6 WC/CRC	HTC/HCR ST6 WC/CRC
4	Sfera	Ball	316 S.S.	316 S.S.	316 S.S.
2	Terminale	Connector	A105/A216 WCB	A479 Tp.304/A351 CF8	A479 Tp.316/A351 CF8M
1	Corpo	Body	A105/A216 WCB	A479 Tp.304/A351 CF8	A479 Tp.316/A351 CF8M

P. No. Parte - Part Name

Materiale - Material

Altri materiali disponibili su richiesta - Other materials are available on request



Dimensionamenti <i>Design</i>	ASME B16.34/API 608/EN 12569 / EN 17292 ASME VIII DIV.1 / EN 12516-1
Estremità flangiate <i>Flanged ends</i>	EN 1092-1 PN 100/PN63 DIN 2637 (PN100)/2636 (PN64) ASME B16.5 CL.600
Collaudo <i>Testing</i>	ASME B16.104 API 598 EN 12266-I ISO 5208 BS 6755-I

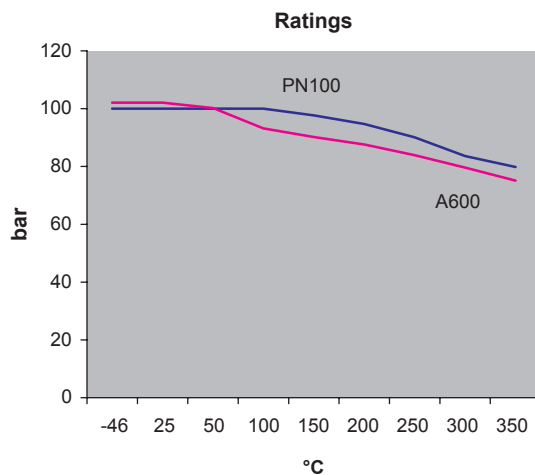
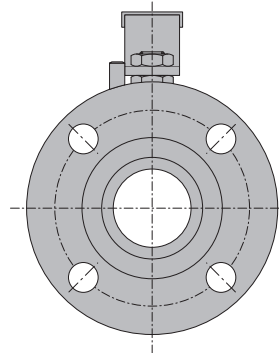
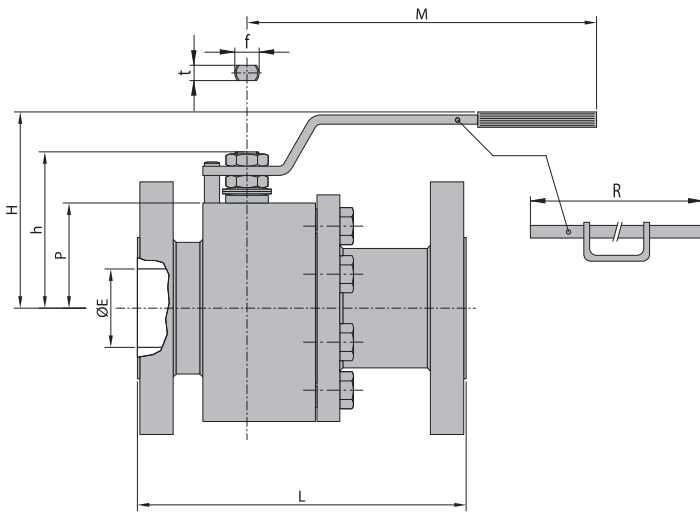
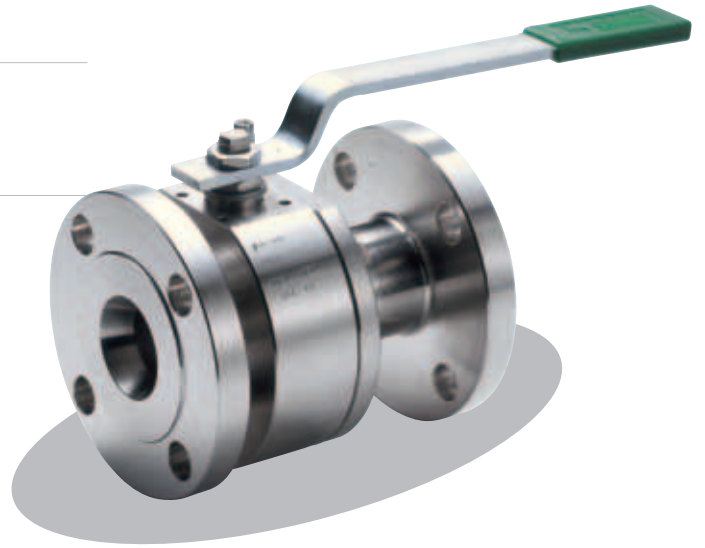

### Dimensioni - outline dimensions

DN	15	20	25	40	50	65	80
Ø"	1/2"	3/4"	1"	1 1/2"	2"	2 1/2"	3"
ØE	14	19	24	38	51	64	76
L	165	191	216	241	292	330	356
M	145	145	275	380	380	440	440
R	—	—	—	—	—	500	500
H	70	75	101	135	146	180	185
h	52	55	76	105	113	136	141
P	33	36	51	65	75	90	95
F/t	10/6	10/6	16/10	22/14	22/14	30/18	30/18
Kg	7	8.5	10	18.5	25	38	50
ISO5211	F03	F03	F05	F07	F07	F10	F10

# VALVOLE A SFERA FLOTTANTE A SEGGI METALLICI

## METAL SEATED FLOATING BALL VALVES



BI-DIRECTIONAL

-46 °C +400 °C

AP

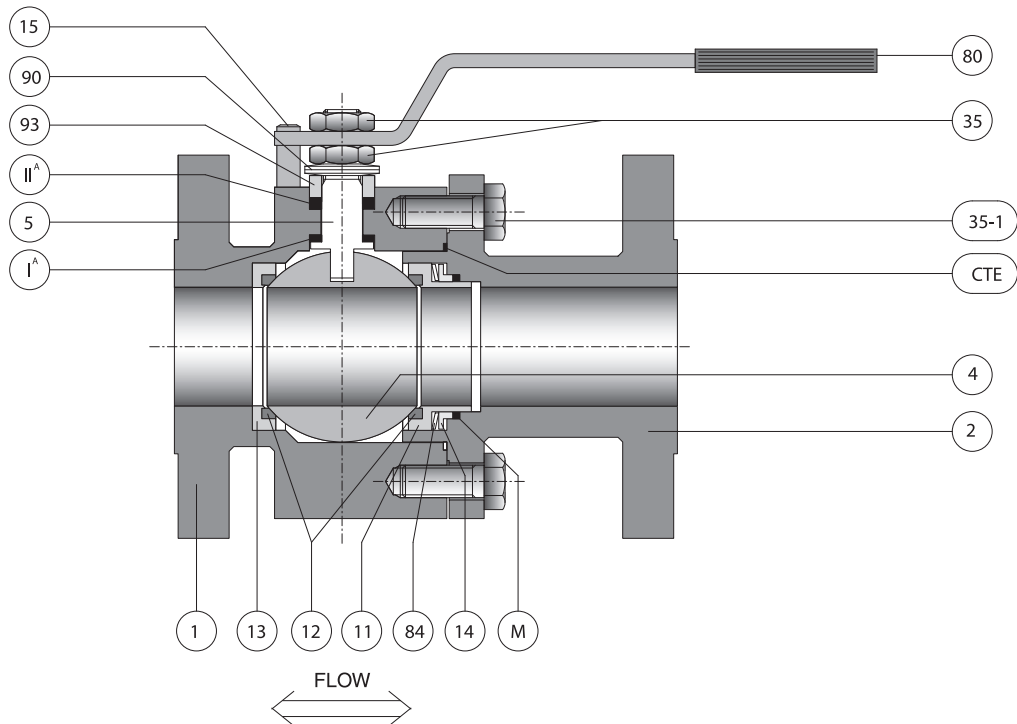

### Materiali base - base materials

CTE	Guarn. Corpo/Terminale	<i>Body connector gasket</i>	Grafoil	Grafoil	Grafoil
M	Guarn. Retroseggio	<i>Backseat gasket</i>	Grafoil	Grafoil	Grafoil
II <sup>A</sup>	Guarnizione Secondaria	<i>Secondary Stem seal</i>	Grafoil	Grafoil	Grafoil
I <sup>A</sup>	Guarnizione Primaria	<i>Primary stem seal</i>	Grafoil	Grafoil	Grafoil
93	Premi Baderna	<i>Gland</i>	304 S.S.	304 S.S.	304 S.S.
90	Molle Stelo	<i>Stem spring</i>	UNS S30100	UNS S30100	UNS S30100
84	Molle Seggio	<i>Seat spring</i>	UNS S30100	UNS S30100	UNS S30100
80	Leva	<i>Handle</i>	Fe37 UNI 7070	Fe37 UNI 7070	Fe37 UNI 7070
35-1	Bulloneria Corpo/Terminale	<i>Body/Connector Bolts</i>	A193 B7 A194 Gr.2H	A193 B8 A 194 Gr.8	A193 BBM A194 Gr.Gr.8M
35	Dadi Stelo	<i>Nut</i>	304 S.S.	304 S.S.	304 S.S.
15	Fermo Leva	<i>Lever stopper</i>	Gr. 8.8 UNI 3740	Gr. 8.8 UNI 3740	Gr. 8.8 UNI 3740
14	Premigrafoil	<i>Compression ring</i>	A479 Tp.316	A479 Tp.316	A479 Tp.316
13	Cassetto Corpo	<i>Body seat holder</i>	A479 Tp.316	A479 Tp.316	A479 Tp.316
12	Seggio	<i>Seat</i>	PENTAFITE ST6 WC/CRC	PENTAFITE ST6 WC/CRC	PENTAFITE ST6 WC/CRC
11	Cassetto Terminale	<i>Connector seat holder</i>	A479 Tp.316	A479 Tp.316	A479 Tp.316.
5	Stelo	<i>Stem</i>	13% Cr. A564 Tp.630 (17/4PH)	A564 Tp.630 (17/4PH)	A564 Tp.630 (17/4PH)
-	Riporto Sfera	<i>Ball coating</i>	HTC/HCR ST6 WC/CRC	HTC/HCR ST6 WC/CRC	HTC/HCR ST6 WC/CRC
4	Sfera	<i>Ball</i>	A479 Tp.316	A479 Tp.316	A479 Tp.316
2	Terminale	<i>Connector</i>	A105	A479 Tp.304	A479 Tp.316
1	Corpo	<i>Body</i>	A105	A479 Tp.304	A479 Tp.316

**P. No. Parte - Part Name**

**Materiale - Material**

**Altri materiali disponibili su richiesta - Other materials are available on request**  
**Altre estremità disponibili su richiesta - Other end connections available on request**

HTC = Nitruri di Titanio (*Titanium Nitrides*); HCR = Nitruri di Cromo (*Chrome Nitrides*); ST6 = Stellite 6 *Detonation Gun/HVOF*  
 WC = Carburi di Tungsteno (*Tungsten Carbides Detonation Gun/HVOF*); CRC = Carburi di Cromo (*Chrome Carbides Detonation Gun/HVOF*)



# AP609

BIDIREZIONALE

Dimensionamenti  
*Design* ASME B16.34/API 608  
ASME VIII DIV.1

Estremità flangiate  
*Flanged ends* ASME B16.5 CL.900  
DIN 2638 (PN160)

Collaudo  
*Testing* ASME B16.104  
API 598  
EN 12266-I  
ISO 5208  
BS 6755-I

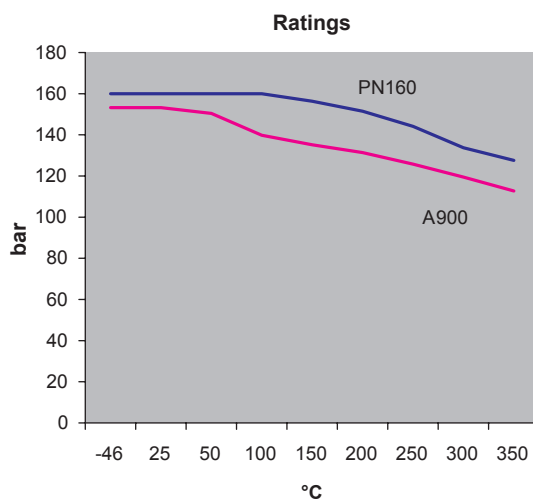
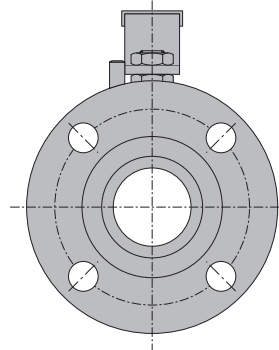
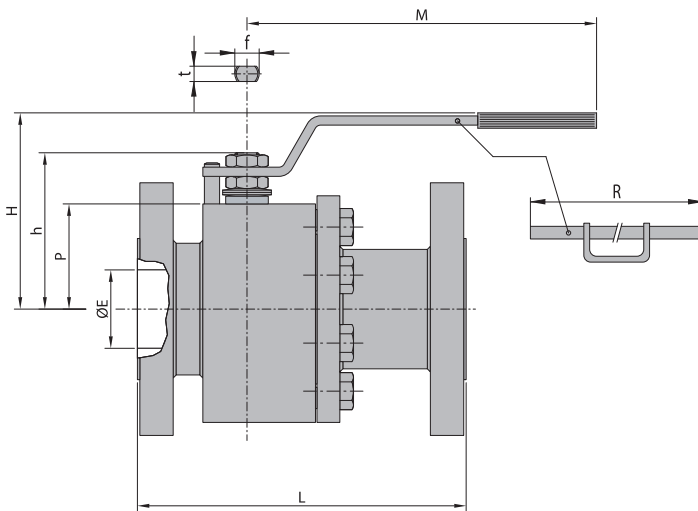
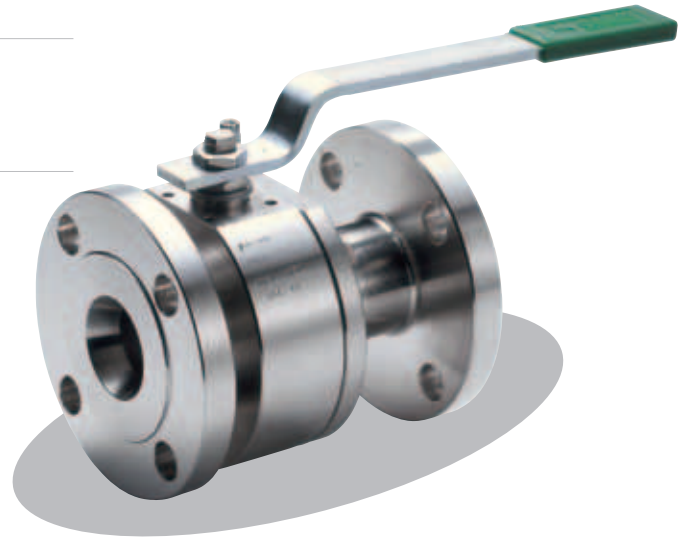

## Dimensioni - *outline dimensions*

DN	15	20	25	40	50
Ø"	1/2"	3/4"	1"	1½"	2"
ØE	13	17	22	35	47
LRF	216	229	254	305	368
LRTJ	216	229	254	305	371
M	275	275	275	380	380
H	101	101	101	135	146
h	75	75	76	105	105
P	48	55	48	65	80
F/t	16/10	16/10	16/10	22/14	22/14
Kg	8.5	10	12	22	30
ISO5211	F05	F05	F05	F07	F07

# VALVOLE A SFERA FLOTTANTE A SEGGI METALLICI

## METAL SEATED FLOATING BALL VALVES



BI-DIRECTIONAL

-46 °C +400 °C

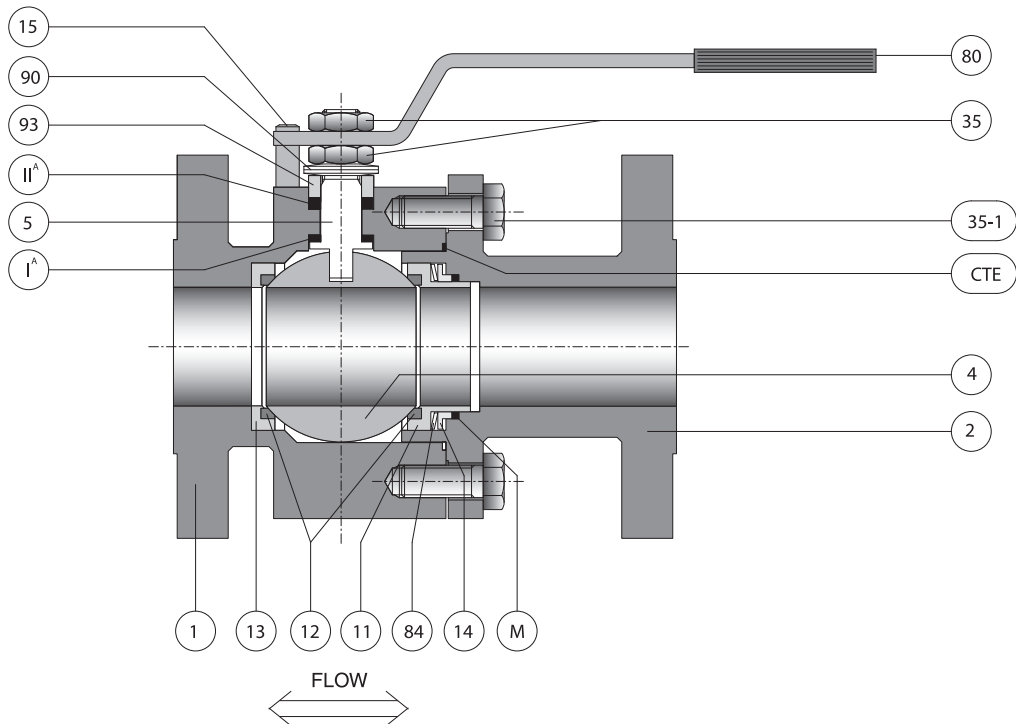

### Materiali base - base materials

CTE	Guarn. Corpo/Terminale	<i>Body connector gasket</i>	Grafoil	Grafoil
M	Guarn. Retroseggio	<i>Backseat gasket</i>	Grafoil	Grafoil
IIA	Guarnizione Secondaria	<i>Secondary Stem seal</i>	Grafoil	Grafoil
IA	Guarnizione Primaria	<i>Primary stem seal</i>	Grafoil	Grafoil
93	Premi Baderna	<i>Gland</i>	304 S.S.	304 S.S.
90	Molle Stelo	<i>Stem spring</i>	UNS S30100	UNS S30100
84	Molle Seggio	<i>Seat spring</i>	UNS S30100	UNS S30100
80	Leva	<i>Handle</i>	Fe37 UNI 7070	Fe37 UN 7070
35-1	Bulloneria Corpo/Terminale	<i>Body/Connector Bolts</i>	A193 B7 A194 Gr.2H	A193 B8M A194 Gr.Gr.8M
35	Dadi Stelo	<i>Nut</i>	304 S.S.	304 S.S.
15	Fermo Leva	<i>Lever stopper</i>	Gr. 8.8 UNI 3740	Gr. 8.8 UNI 3740
14	Premigrafoil	<i>Compression ring</i>	A479 Tp.316	A479 Tp.316
13	Cassetto Corpo	<i>Body seat holder</i>	A479 Tp.316	A479 Tp.316
12	Seggio	<i>Seat</i>	PENTAFITE	PENTAFITE
11	Cassetto Terminale	<i>Connector seat holder</i>	A479 Tp.316	A479 Tp.316.
5	Stelo	<i>Stem</i>	13% Cr. A564 Tp.630 (17/4PH)	A564 Tp.630 (17/4PH)
-	Riporto Sfera	<i>Ball coating</i>	HTC/HCR ST6 WC/CRC	HTC/HCR ST6 WC/CRC
4	Sfera	<i>Ball</i>	A182 F51	A182 F51
2	Terminale	<i>Connector</i>	A105	A479 Tp.316
1	Corpo	<i>Body</i>	A105	A479 Tp.316

**P. No. Parte - Part Name**

**Materiale - Material**

**Altri materiali disponibili su richiesta – Other materials are available on request**  
**Altre estremità disponibili su richiesta – Other end connections available on request**

HTC = Nitruri di Titanio (*Titanium Nitrides*); HCR = Nitruri di Cromo (*Chrome Nitrides*); ST6 = Stellite 6 *Detonation Gun/HVOF*  
 WC = Carburi di Tungsteno (*Tungsten Carbides Detonation Gun/HVOF*); CRC = Carburi di Cromo (*Chrome Carbides Detonation Gun/HVOF*)





# AP50

## BIDIREZIONALE

Dimensionamenti <i>Design</i>	ASME B16.34 / EN 12569 / API 608 / EN 17292 ASME VIII DIV.1 / EN 12516-1
Estremità flangiate <i>Flanged ends</i>	ASME B 16.5 CL.300 EN 1092-1 PN 25 / PN 40 DIN 2634 (PN 25) / 2635 (PN 40)
Estremità BW <i>BW ends</i>	ASME B 16.25
Collaudo <i>Testing</i>	ASME B16.104 API 598 EN 12266-I ISO 5208 BS 6755-I

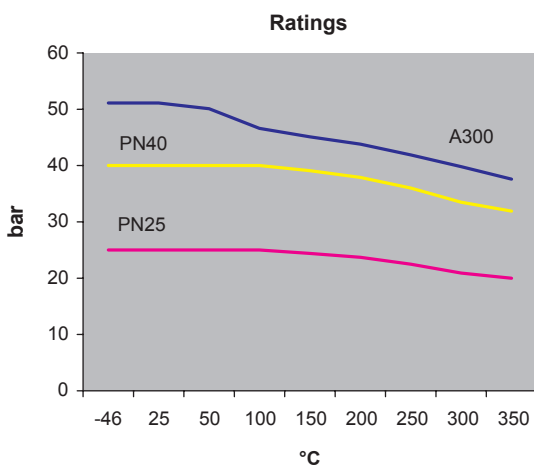
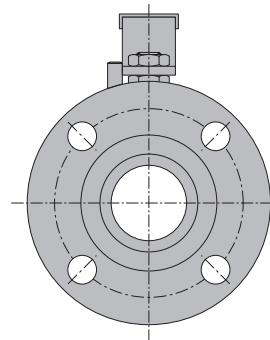
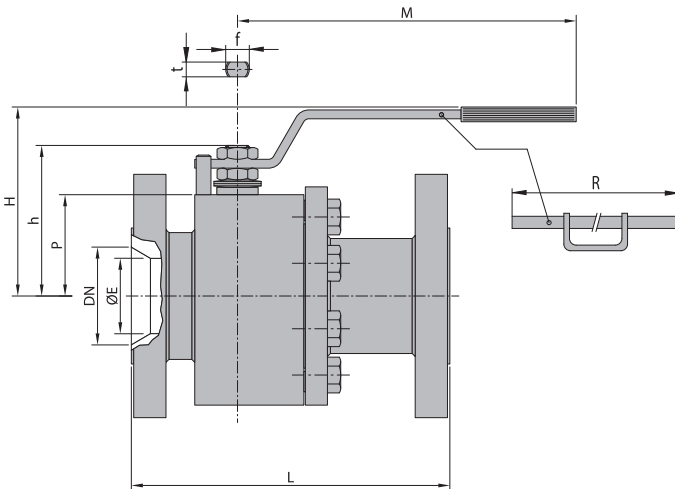

### Dimensioni - outline dimensions

DN	50	65	80	100	150	200
Ø"	2"	2½"	3"	4"	6"	8"
ØE	38	51	64	76	102	152
L	216	241	283	305	403	419
M	275	275	380	380	440	.. <sup>(1)</sup>
R	-	-	-	500	800	-
H	118	126	139	144	212	-
h	96	103	122	128	158	220
P	63	68.5	82	88.5	111	153
F/t	16/10	16/10	22/14	22/14	30/18	45/30
Kg	18.5	22.5	32	45	70	105
ISO5211	F05	F05	F07	F07	F10	F14

<sup>(1)</sup> É raccomandato riduttore manuale - *Manual gear recommended*

# VALVOLE A SFERA FLOTTANTE A SEGGI METALLICI

## METAL SEATED FLOATING BALL VALVES



BI-DIRECTIONAL

-46 °C +400 °C

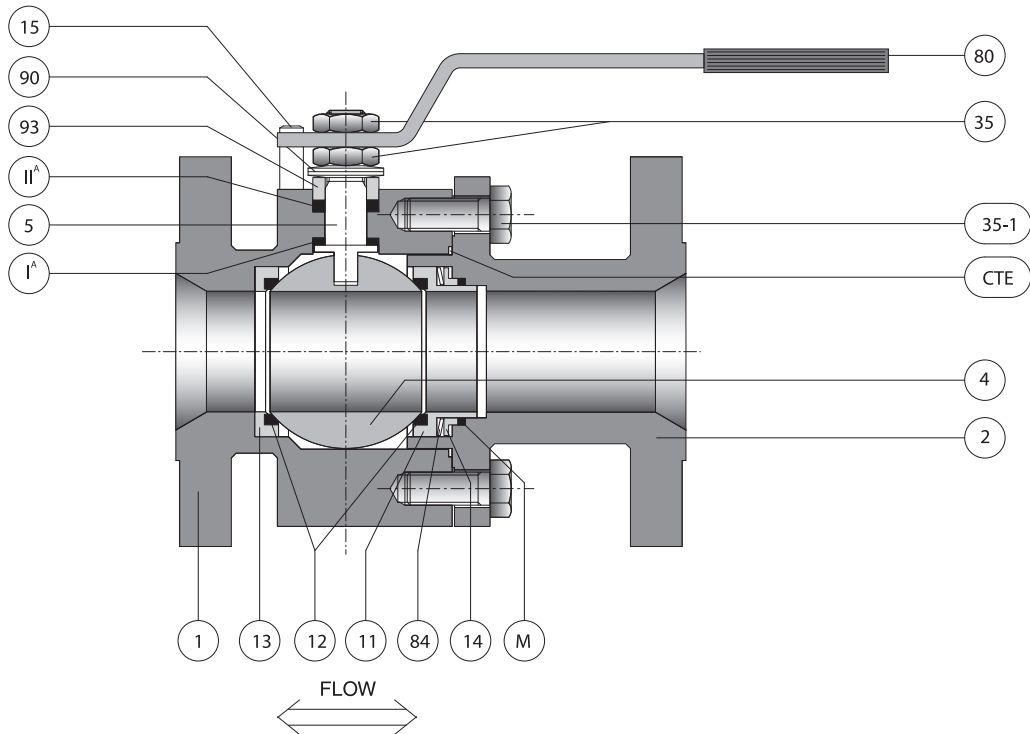

### Materiali base - base materials

CTE	Guarn. Corpo/Terminale	<i>Body connector gasket</i>	Grafoil	Grafoil	Grafoil
M	Guarn. Retroseggio	<i>Backseat gasket</i>	Grafoil	Grafoil	Grafoil
IIA	Guarnizione Secondaria	<i>Secondary Stem seal</i>	Grafoil	Grafoil	Grafoil
IA	Guarnizione Primaria	<i>Primary stem seal</i>	Grafoil	Grafoil	Grafoil
93	Premi Baderna	<i>Gland</i>	304 S.S.	304 S.S.	304 S.S.
90	Molle Stelo	<i>Stem spring</i>	UNS S30100	UNS S30100	UNS S30100
84	Molle Seggio	<i>Seat spring</i>	UNS S30100	UNS S30100	UNS S30100
80	Leva	<i>Handle</i>	Fe37 UNI 7070	Fe37 UNI 7070	Fe37 UNI 7070
35-1	Bulloneria Corpo/Terminale	<i>Body/Connector Bolts</i>	A193 B7 A194 Gr.2H	A193 B8 A 194 Gr. 8	A193 B8M A194 Gr.Gr.8M
35	Dadi Stelo	<i>Nut</i>	304 S.S.	304 S.S.	304 S.S.
15	Fermo Leva	<i>Lever stopper</i>	Gr. 8.8 UNI 3740	Gr. 8.8 UNI 3740	Gr. 8.8 UNI 3740
14	Premigrafoil	<i>Compression ring</i>	A479 Tp.316	A479 Tp.316	A479 Tp.316
13	Cassetto Corpo	<i>Body seat holder</i>	A479 Tp.316	A479 Tp.316	A479 Tp.316
12	Seggio	<i>Seat</i>	PENTAFITE ST6 WC/CRC	PENTAFITE ST6 WC/CRC	PENTAFITE ST6 WC/CRC
11	Cassetto Terminale	<i>Connector seat holder</i>	A479 Tp.316	A479 Tp.316	A479 Tp.316.
5	Stelo	<i>Stem</i>	13% Cr. A564 Tp.630 (17/4PH)	A564 Tp.630 (17/4PH)	A564 Tp.630 (17/4PH)
-	Riporto Sfera	<i>Ball coating</i>	HTC/HCR ST6 WC/CRC	HTC/HCR ST6 WC/CRC	HTC/HCR ST6 WC/CRC
4	Sfera	<i>Ball</i>	316 S.S	316 S.S	316 S.S
2	Terminale	<i>Connector</i>	A105/A216 WCB	A479 Tp.304/A351 CF8	A479 Tp.316/A351 CF8M
1	Corpo	<i>Body</i>	A105/A216 WCB	A479 Tp.304/A351 CF8	A479 Tp.316/A351 CF8M

**P. No. Parte - Part Name**

**Materiale - Material**

**Altri materiali disponibili su richiesta – Other materials are available on request**  
**Altre estremità disponibili su richiesta – Other end connections available on request**

HTC = Nitruri di Titanio (*Titanium Nitrides*); HCR = Nitruri di Cromo (*Chrome Nitrides*); ST6 = Stellite 6 *Detonation Gun/HVOF*  
 WC = Carburi di Tungsteno (*Tungsten Carbides Detonation Gun/HVOF*); CRC = Carburi di Cromo (*Chrome Carbides Detonation Gun/HVOF*)



Dimensionamenti <i>Design</i>	ASME B16.34 / EN 12569 / API 608 / EN 17292 ASME VIII DIV.1 / EN 12516-1
Estremità flangiate <i>Flanged ends</i>	ASME B 16.5 CL.150 EN 1092-1 PN 16 DIN 2633 PN 16
Collaudo <i>Testing</i>	ASME B16.104 API 598 EN 12266-I ISO 5208 BS 6755-I

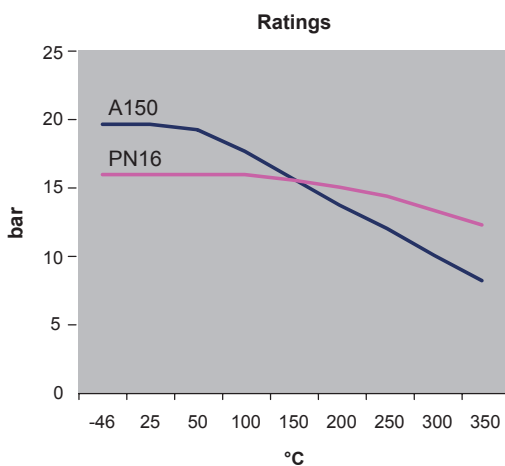
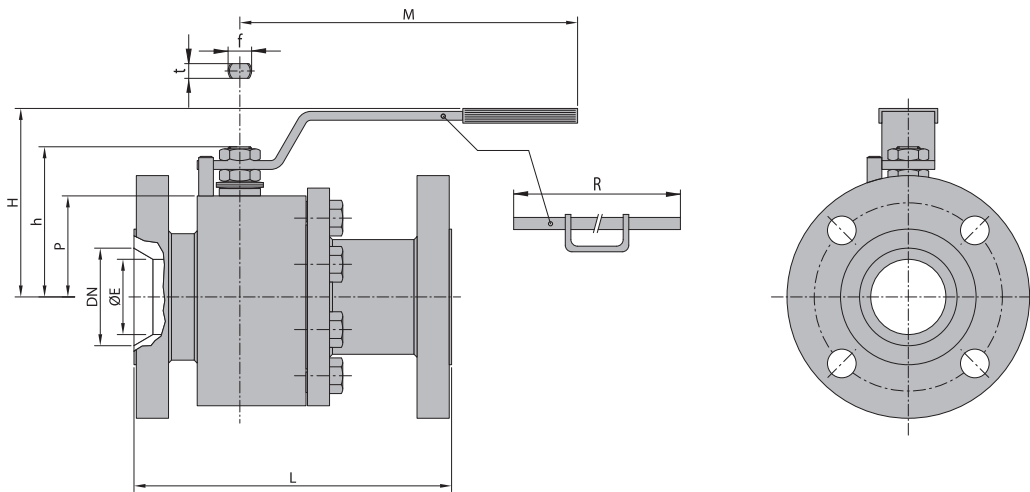
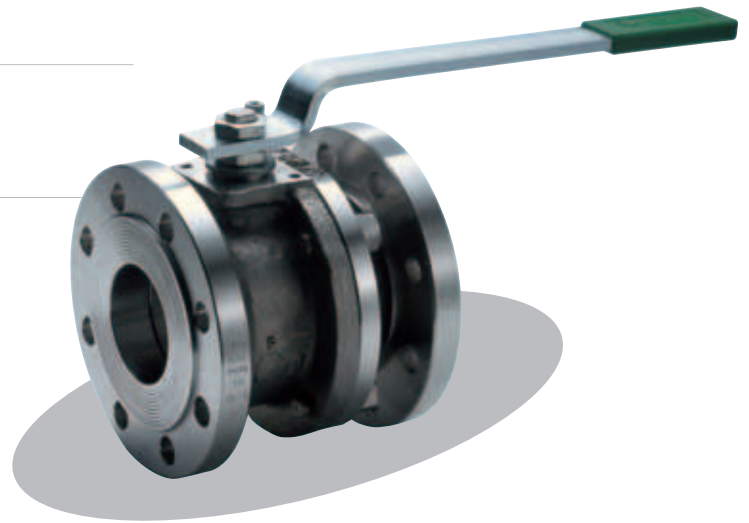

Dimensioni - *outline dimensions*

DN	50	65	80	100	125	150	200
Ø"	2"	2½"	3"	4"	5"	6"	8"
ØE	38	51	64	76	102	102	152
L	178	190	203	229	254	267	292
M	275	275	380	380	440	440	<sup>0)</sup>
R	-	-	-	-	500	500	800
H	118	126	139	144	212	212	-
h	96	103	122	128	158	158	220
P	63	68.5	82	88.5	111	111	153
F/t	16/10	16/10	22/14	22/14	30/18	30/18	45/30
Kg	13	17	26	34	38	43	68
ISO5211	F05	F05	F07	F07	F10	F10	F14

<sup>0)</sup> È raccomandato riduttore manuale - *Manual gear recommended*

# VALVOLE A SFERA FLOTTANTE A SEGGI METALLICI

## METAL SEATED FLOATING BALL VALVES



BI-DIRECTIONAL

-46 °C +400 °C

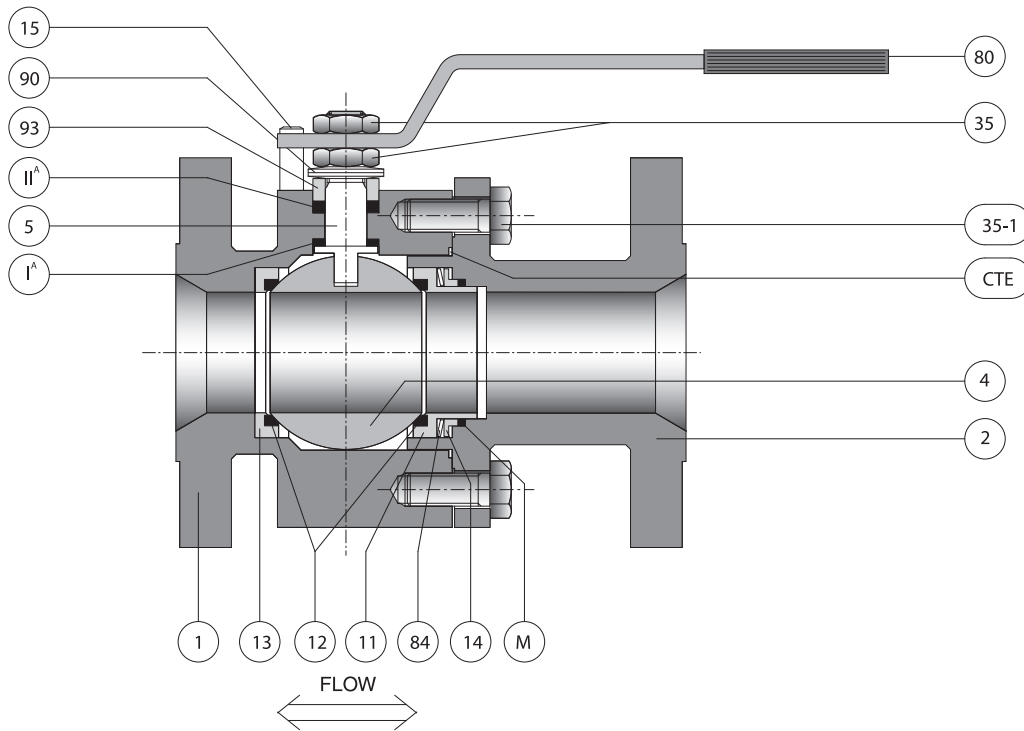

### Materiali base - base materials

CTE	Guarn. Corpo/Terminale	Body connector gasket	Grafoil	Grafoil	Grafoil
M	Guarn. Retroseggio	Backseat gasket	Grafoil	Grafoil	Grafoil
II <sup>A</sup>	Guarnizione Secondaria	Secondary Stem seal	Grafoil	Grafoil	Grafoil
I <sup>A</sup>	Guarnizione Primaria	Primary stem seal	Grafoil	Grafoil	Grafoil
93	Premi Baderna	Gland	304 S.S.	304 S.S.	304 S.S.
90	Molle Stelo	Stem spring	UNS S30100	UNS S30100	UNS S30100
84	Molle Seggio	Seat spring	UNS S30100	UNS S30100	UNS S30100
80	Leva	Handle	Fe37 UNI 7070	Fe37 UNI 7070	Fe37 UNI 7070
35-1	Bulloneria Corpo/Terminale	Body/Connector Bolts	A193 B7 A194 Gr.2H	A193 B8 A 194 Gr.8	A193 B8M A194 Gr.Gr.8M
35	Dadi Stelo	Nut	304 S.S.	304 S.S.	304 S.S.
15	Fermo Leva	Lever stopper	Gr. 8.8 UNI 3740	Gr. 8.8 UNI 3740	Gr. 8.8 UNI 3740
14	Premigrafoil	Compression ring	A479 Tp.316	A479 Tp.316	A479 Tp.316
13	Cassetto Corpo	Body seat holder	A479 Tp.316	A479 Tp.316	A479 Tp.316
12	Seggio	Seat	PENTAFITE ST6 WC/CRC	PENTAFITE ST6 WC/CRC	PENTAFITE ST6 WC/CRC
11	Cassetto Terminale	Connector seat holder	A479 Tp.316	A479 Tp.316	A479 Tp.316.
5	Stelo	Stem	13% Cr. A564 Tp.630 (17/4PH)	A564 Tp.630 (17/4PH)	A564 Tp.630 (17/4PH)
-	Riporto Sfera	Ball coating	HTC/HCR ST6 WC/CRC	HTC/HCR ST6 WC/CRC	HTC/HCR ST6 WC/CRC
4	Sfera	Ball	A479 Tp.316	A479 Tp.316/A351 CF8	A479 Tp.316/A351 CF8M
2	Terminale	Connector	A105/A216 WCB	A479 Tp.304/A351 CF8	A479 Tp.316/A351 CF8M
1	Corpo	Body	A105/A216 WCB	A479 Tp.304/A351 CF8	A479 Tp.316/A351 CF8M

P. No. Parte - Part Name

Materiale - Material

Altri materiali disponibili su richiesta – Other materials are available on request  
 Altre estremità disponibili su richiesta – Other end connections available on request

HTC = Nitruri di Titanio (Titanium Nitrides); HCR = Nitruri di Cromo (Chrome Nitrides); ST6 = Stellite 6 Detonation Gun/HVOF  
 WC = Carburi di Tungsteno (Tungsten Carbides Detonation Gun/HVOF); CRC = Carburi di Cromo (Chrome Carbides Detonation Gun/HVOF)



# AP503

BIDIREZIONALE

Dimensionamenti <i>Design</i>	ASME B16.34/API 608/EN 12569 / EN 17292 ASME VIII DIV.1 / EN 12516-1
Estremità flangiate <i>Flanged ends</i>	EN 1092-1 PN 100/PN63 DIN 2637 (PN100)/2636 (PN64) ASME B16.5 CL.600
Collaudo <i>Testing</i>	ASME B16.104 API 598 EN 12266-I ISO 5208 BS 6755-I

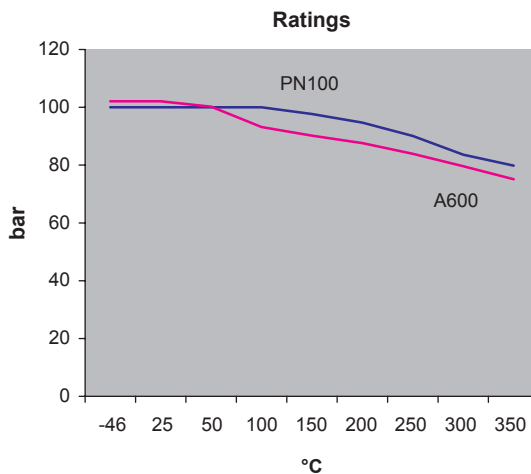
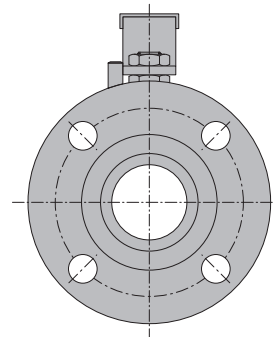
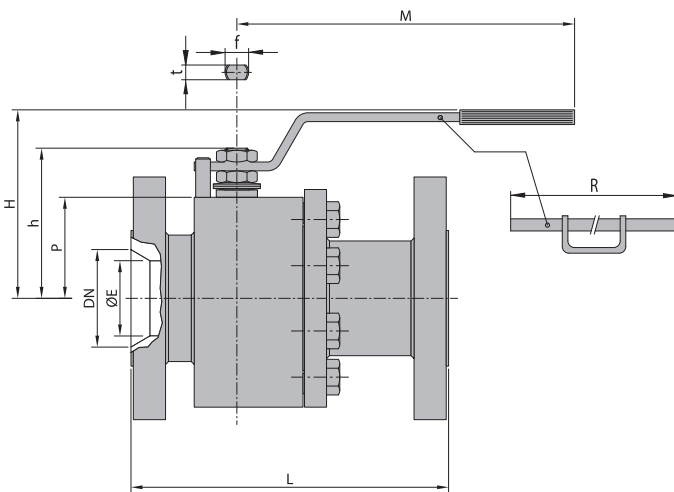
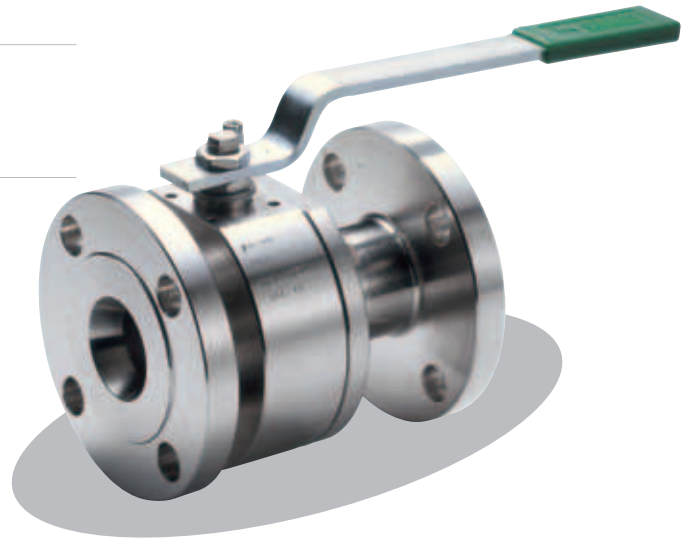

## Dimensioni - outline dimensions

DN	50	65	80	100
Ø"	2"	2½"	3"	4"
ØE	38	51	51	76
L	292	330	356	432
M	380	380	380	440
R	-	-	-	500
H	135	146	146	185
h	104	115	115	141
P	65	75	75	95
F/t	22/14	22/14	22/14	30/18
Kg	22	33	38	65
ISO5211	F07	F07	F07	F10

# VALVOLE A SFERA FLOTTANTE A SEGGI METALLICI

## METAL SEATED FLOATING BALL VALVES



BI-DIRECTIONAL

-46 °C +400 °C

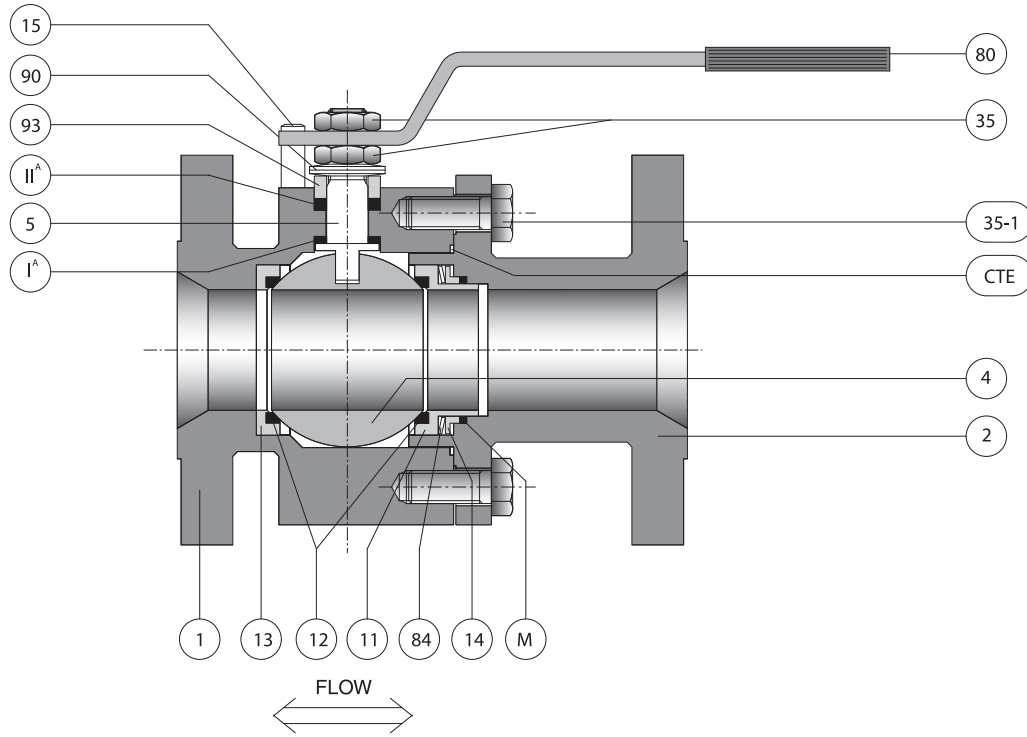

### Materiali base - base materials

CTE	Guarn. Corpo/Terminale	Body connector gasket	Grafoil	Grafoil	Grafoil
M	Guarn. Retroseggio	Backseat gasket	Grafoil	Grafoil	Grafoil
II <sup>A</sup>	Guarnizione Secondaria	Secondary Stem seal	Grafoil	Grafoil	Grafoil
I <sup>A</sup>	Guarnizione Primaria	Primary stem seal	Grafoil	Grafoil	Grafoil
93	Premi Baderna	Gland	304 S.S	304 S.S	304 S.S
90	Molle Stelo	Stem spring	UNS S30100	UNS S30100	UNS S30100
84	Molle Seggio	Seat spring	UNS S30100	UNS S30100	UNS S30100
80	Leva	Handle	Fe37 UNI 7070	Fe37 UNI 7070	Fe37 UNI 7070
35-1	Bulloneria Corpo/Terminale	Body/Connector Bolts	A193 B7 A194 Gr.2H	A193 B8 A 194 Gr.8	A193 B8M A194 Gr.Gr.8M
35	Dadi Stelo	Nut	304 S.S.	304 S.S.	304 S.S.
15	Fermo Leva	Lever stopper	Gr. 8.8 UNI 3740	Gr. 8.8 UNI 3740	Gr. 8.8 UNI 3740
14	Premigrafoil	Compression ring	A479 Tp.316	A479 Tp.316	A479 Tp.316
13	Cassetto Corpo	Body seat holder	A479 Tp.316	A479 Tp.316	A479 Tp.316
12	Seggio	Seat	PENTAFITE ST6 WC/CRC	PENTAFITE ST6 WC/CRC	PENTAFITE ST6 WC/CRC
11	Cassetto Terminale	Connector seat holder	A479 Tp.316	A479 Tp.316	A479 Tp.316.
5	Stelo	Stem	13% Cr. A564 Tp.630 (17/4PH)	A564 Tp.630 (17/4PH)	A564 Tp.630 (17/4PH)
-	Riporto Sfera	Ball coating	HTC/HCR ST6 WC/CRC	HTC/HCR ST6 WC/CRC	HTC/HCR ST6 WC/CRC
4	Sfera	Ball	A479 Tp.316 /	A479 Tp.316 A351 CF8	A479 Tp.316 A351 CF8M
2	Terminale	Connector	A105	A479 Tp.304	A479 Tp.316
1	Corpo	Body	A105	A479 Tp.304	A479 Tp.316

P. No. Parte - Part Name

Materiale - Material

Altri materiali disponibili su richiesta - Other materials are available on request

Altre estremità disponibili su richiesta - Other end connections available on request

HTC = Nitruri di Titanio (Titanium Nitrides); HCR = Nitruri di Cromo (Chrome Nitrides); ST6 = Stellite 6 Detonation Gun/HVOF

WC = Carburi di Tungsteno (Tungsten Carbides Detonation Gun/HVOF); CRC = Carburi di Cromo (Chrome Carbides Detonation Gun/HVOF)



## BIDIREZIONALE DOUBLE BLOCK AND BLEED SCARICO AUTOMATICO DEL CORPO

Dimensionamenti <i>Design</i>	ASME B16.34/API 608/EN 12569 / EN 17292 ASME VIII DIV.1 / EN 12516-1
Estremità flangiate <i>Flanged ends</i>	ASME B16.5 CL.150/300/600/900/1500 EN 1092-1 PN 10/16/25/40/63/100 DIN 2632/2633/2634/2635/2636/2637/2638

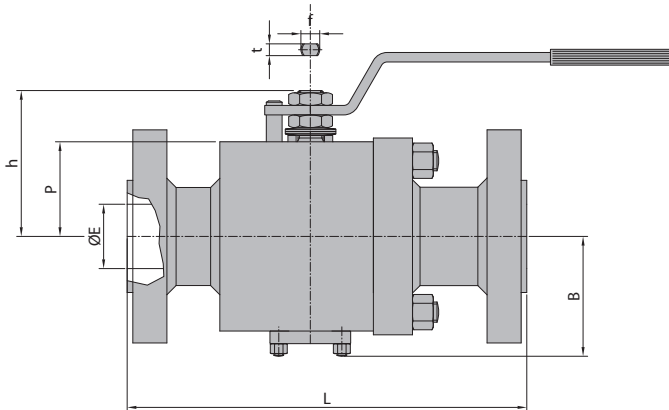

Dimensioni - *outline dimensions*

	DN	15	20	25	40	50	80	100	150		
	Ø	1/2"	3/4"	1"	1½"	2"	3"	4"	6"	RB	
	ØE	14	19	24	38	51	76	102	152		
Cl.150	L	140	152	165	191	178	203	229	394	PN10-16	
	h	82	82	83	96	103	128	157	157		
	P	48	48	50	63	69	89	111	111		
	B	73	73	68	81	87	114	125	125		
	F/t	16/10	16/10	16/10	16/10	16/10	22/14	30/18	30/18	30/18	
	ISO 5211	F05	F05	F05	F05	F05	F07	F10	F10	F10	
Cl.300	L	140	152	165	191	216	283	305	403	PN25-40	
	h	82	82	83	96	103	128	180	180		
	P	48	48	50	63	69	89	114	114		
	B	73	73	68	81	87	114	125	125		
	F/t	16/10	16/10	16/10	16/10	16/10	22/14	45/30	45/30	45/30	
	ISO 5211	F05	F05	F05	F05	F05	F07	F14	F14	F14	
Cl.600	L	165	191	216	241	292	356	432	559	PN64-100	
	h	82	82	83	104	112	143	199	199		
	P	48	48	50	65	75	95	124	124		
	B	73	73	68	83	95	115	159	159		
	F/t	16/10	16/10	16/10	22/14	22/14	30/18	45/30	45/30	45/30	
	ISO 5211	F05	F05	F05	F07	F07	F10	F14 <sup>(1)</sup>	F14 <sup>(1)</sup>	F14 <sup>(1)</sup>	
Cl.900	L	216	229	254	305	268				PN160	
	h	79	79	79	104	116					
	P	55	55	55	65	75					
	B	73	73	73	98	100					
	F/t	16/10	16/10	16/10	22/14	22/14					
	ISO 5211	F05	F05	F05	F07	F07					
Cl.1500	L	216	229	254						PN250	
	h	79	79	79							
	P	55	55	55							
	B	73	73	73							
	F/t	16/10	16/10	16/10							
	ISO 5211	F05	F05	F05							



# VALVOLE A SFERA VINCOLATA A SEGGI METALLICI

## TRUNNION MOUNTED METAL SEATED BALL VALVES



BI-DIRECTIONAL  
DOUBLE BLOCKED AND BLEED  
AUTOMATIC BODY CAVITY RELIEF

-46 °C +400 °C

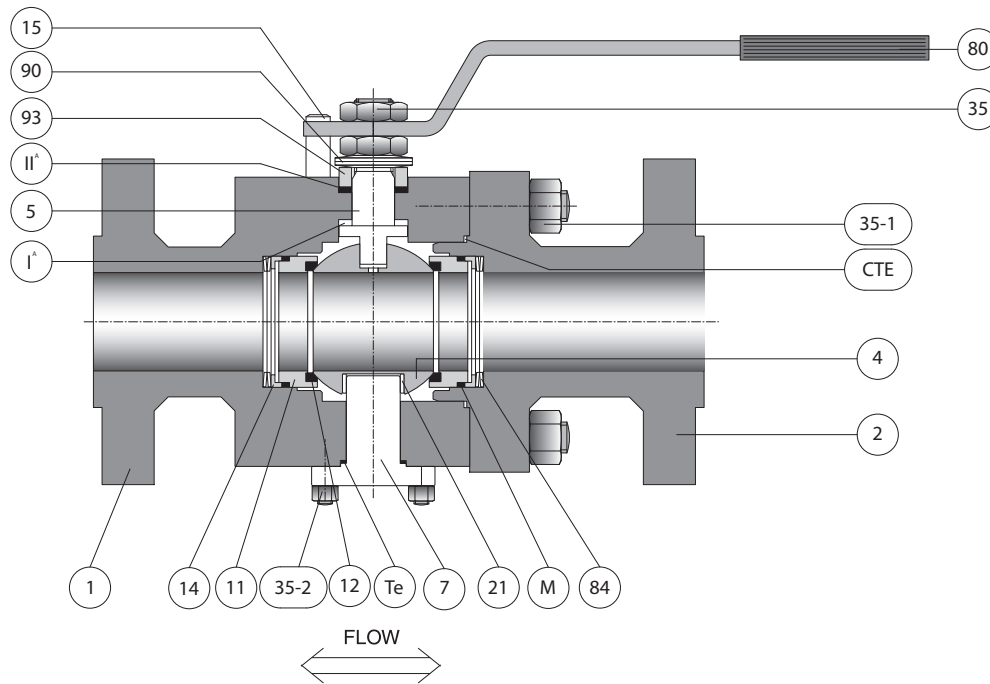

### Materiali base - base materials

Te	Guarn. Corpo/Coperchio	Body Cover gasket	Grafoil	Grafoil
CTe	Guarn. Corpo/Terminale	Body connector gasket	Grafoil	Grafoil
M	Guarn. Retroseggio	Backseat gasket	Grafoil	Grafoil
IIA	Guarnizione Secondaria	Secondary Stem seal	Grafoil	Grafoil
IA	Guarnizione Primaria	Primary stem seal	Grafoil	Grafoil
93	Premi Baderna	Gland	304 s.s.	304 s.s.
90	Molle Stelo	Stem spring	UNS S30100	UNS S30100
84	Molle Seggio	Seat spring	UNS S30100	UNS S30100
80	Leva	Handle	Fe37 UNI 7070	Fe37 UNI 7070
35-2	BulloneriaCorpo/Coperchio	Body/Cover Bolts	A193 B7 A194 Gr.2H	A193 B8M A194 Gr.Gr.8M
35-1	BulloneriaCorpo/Terminale	Body/Connector Bolts	A193 B7 A194 Gr.2H	A193 B8M A194 Gr.Gr.8M
35	Dadi Stelo	Nut	304 S.S.	304 S.S.
21	Bussola Strisciamento	Trunnion Bearing	DU/BM	DU/BM
15	Fermo Leva	Lever stopper	Gr. 8.8 UNI 3740	Gr. 8.8 UNI 3740
14	Premigrafoil	Compression ring	A479 Tp.316	A479 Tp.316
13	Cassetto Corpo	Body seat holder	A479 Tp.316	A479 Tp.316
12	Seggio	Seat	PENTAFITE ST6 WC/CRC	PENTAFITE ST6 WC/CRC
11	Cassetto Terminale	Connector seat holder	A479 Tp.316	A479 Tp.316.
6	Coperchio Inferiore	Lower Cover	A105	
5	Stelo	Stem	420 s.s.A564 Tp.630(17/4PH)	A564 Tp.630(17/4PH)
-	Riporto Sfera	Ball coating	HTC/HCR ST6 WC/CRC	HTC/HCR ST6 WC/CRC
4	Sfera	Ball	316 s.s.	316 s.s.
2	Terminale	Connector	A105	A479 Tp.316
1	Corpo	Body	A105	A479 Tp.316

**P. No. Parte - Part Name**

**Materiale - Material**

**Altri materiali disponibili su richiesta - Other materials are available on request**  
**Altre estremità disponibili su richiesta - Other end connections available on request**



## BIDIREZIONALE DOUBLE BLOCK AND BLEED SCARICO AUTOMATICO DEL CORPO

Dimensionamenti ASME B16.34 / EN 12569 / EN 17292 / ASME VIII  
DIV.1 EN 12516-1

Estremità flangiate ASME B16.5 CL. 150/300/600  
EN 1092-1 PN 10/16/25/40/63/100  
DIN 2632-33-34-35-36-37-38  
GOST 54432 / GOST 12815

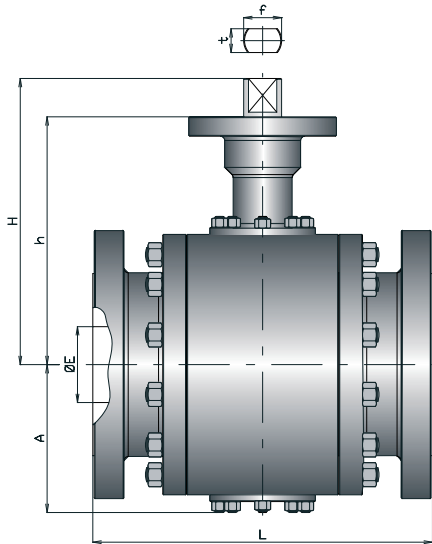

Dimensioni - *outline dimensions*

	DN	150	200	250
	Ø"	6"	8"	10"
ANSI 150	ØE	152	203	254
PN10 - 16	L	394	457	533
	A	175	210	255
	h	239	266	329
	H	290	317	408
	f / t	45 / 30	45 / 30	55 / 40
	ISO 5211	F14	F14	F14
ANSI 300	ØE	152	203	254
PN25 - 40	L	403	502	568
	A	175	210	255
	h	244	266	329
	H	290	320	408
	f / t	45 / 30	45 / 30	55 / 40
	ISO 5211	F14	F14	F14
ANSI 600	ØE	152	203	248
PN64 - 100	L	559	660	787
	A	185	235	275
	h	244	298	329
	H	290	377	408
	f / t	45 / 30	55 / 40	55 / 40
	ISO 5211	F14	F16	F16

# VALVOLE A SFERA VINCOLATA A SEGGI METALLICI

## TRUNNION MOUNTED METAL SEATED BALL VALVES



BI-DIRECTIONAL  
DOUBLE BLOCKED AND BLEED  
AUTOMATIC BODY CAVITY RELIEF

-46 °C +400 °C

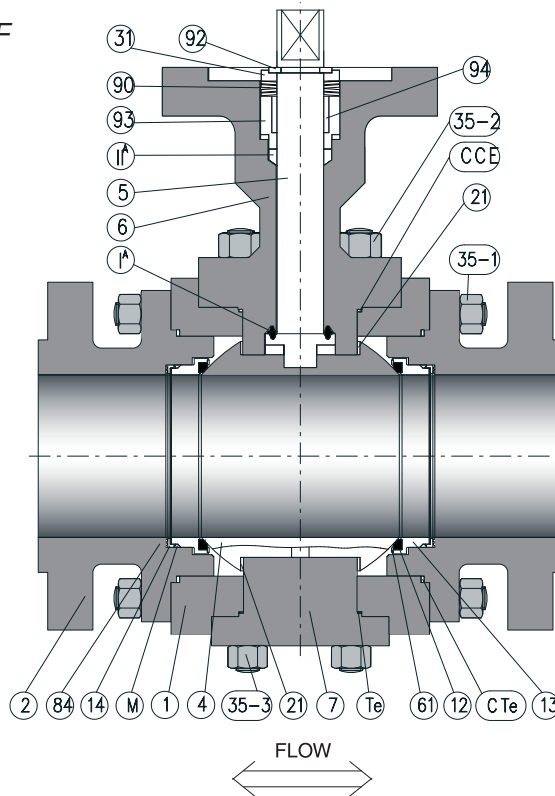

### Materiali base - base materials

TE	Guarnizione Corpo / Cop. Inf.	Lower Cover Gasket	Grafoil	
CCE	Guarnizione Corpo / Cop. Sup.	Upper Cover Gasket	Grafoil	
CTE	Guarnizione Corpo / Terminale	Body / Connector Gasket	Grafoil	
M	Guarnizione Retroseggio	Seat Gasket	Grafoil	
Il ^	Guarnizione Secondaria	Secondary Stem Seal	Grafoil	
I ^	Guarnizione Primaria	Primary Stem Seal	Grafoil	
94	Bussola Strisciamento Stelo	Stem Plain Bearing	DU	
93	Premi Baderna	Gland	316 s.s.	
92	Anello D'arresto Stelo	Stem Retaining Ring	316 s.s.	
90	Molle Stelo	Stem Spring	301 s.s.	
84	Molle Seggio	Seat Spring	X750	
61	Supporto Seggio	Seat Support	316 s.s.	
35-3	Bulloneria Corpo / Cop. Inf.	Lower Cover Bolts	B7/2H	B8/Gr.8
35-2	Bulloneria Corpo / Cop. Sup.	Upper Cover Bolts	B7/2H	B8/Gr.8
35-1	Bulloneria Corpo / Terminale	Body / Connector Bolts	B7/2H	B8/Gr.8
31	Rondella Premi Molla	Stem Spring Compression Ring	316 s.s.	
21	Bussola Strisciamento Trunn.	Trunnion Plain Bearing	DU / BM	
14	Premigrafoil	Compression Ring	316 s.s.	
13	Cassetto	Seat Holder	316 s.s.	
12	Seggio	Seat Insert	PENTAFITE ST6 WC/CRC	
7	Coperchio Inf.	Lower Cover	A105	316 s.s.
6	Coperchio Sup.	Upper Cover	A105	316 s.s.
5	Stelo	Stem	410 s.s.	316 s.s.
-	Rivestimento Sfera	Ball Coating	HCR/HTC ST6 WC/CRC	
4	Sfera	Ball	316 s.s.	
2	Terminale	Body Connector	A105	316 s.s.
1	Corpo	Body	A105	316 s.s.

P.No. Parte - Part name

Materiale - Material

HTC = Nitruri di Titanio (Titanium Nitrides); HCR = Nitruri di Cromo (Chrome Nitrides); ST6 = Stellite 6 Detonation Gun/HVOF  
WC = Carburi di Tungsteno (Tungsten Carbides Detonation Gun/HVOF); CRC = Carburi di Cromo (Chrome Carbides Detonation Gun/HVOF)



## Accessori AP AP accessories

Leva prolunga SIP per linee coibentate  
*SIP lever elongation for insulated piping systems*

---



Riduttore - *Manual gear*

---

Prolunga stelo - *Stem elongation*

---



Attuatori pneumatici semplice o doppio effetto  
*Single or double acting actuators*

---

Attuatori Elettrici e Idraulici  
Electric and Hydraulic Actuators



penta s.r.l.

WSS



MODELLO / **MODEL**

**WSS**

**Fire-Safe**  
Certificate  
API 607 V ED.  
ISO 10497

**Ta-Luft**  
Approved  
(c/w 100 mm stem elongation)

**CE**  
Directive 2014/68/UE  
"PED"

**Ex** II2G c IIC TX  
II2D c IIC TX  
Directive 2014/34/UE  
"ATEX"



## Serie WSS

Questo modello si può considerare una evoluzione dei modelli AP10 e AP11 studiato per rendere più agevole la manutenzione di valvole wafer utilizzate su servizi particolarmente sporchi. L'utilizzo della costruzione Split Body evita il grippaggio delle ghiere di chiusura utilizzate nelle AP10 e AP11.

Lo scarico automatico delle sovrappressioni nel corpo valvola insieme alla caratteristica della bi-direzionalità rendono il modello tecnicamente performante.

Disponibile anche con camicia di riscaldamento (in questo caso assume denominazione WSJ).

Tutte le valvole sono predisposte con foratura ISO 5211 per montaggio attuatori.

Scartamenti in accordo a EN558 serie 100 (DN 3", 4", 6"), 101 (DN 1/2", 3/4") e 107.

## WSS Series

This model can be considered an evolution of models AP10 and AP11 because designed to make easier the maintenance on those wafer valves used on dirty services.

The use of a split body wafer design eliminates the possibility of galling on end ring nut like possible in standard AP10 or AP11.

The automatic body cavity pressure relief together with Bi-directionality make this model of technical high level.

Available with heating jacket also (in this case called WSJ)

All valves are provided with ISO 5211 top drilling.

Face to face are according to EN558 serie 100 (DN 3", 4", 6"), 101 (DN 1/2", 3/4") e 107.



## GRADO DI TENUTA - TIGHTNESS

Tutte le valvole PENTA modello WSS sono collaudate per verificarne la TENUTA PERFETTA (perdita zero alla prova idraulica dei seggi secondo ANSI B16.34 e a 6 bar con aria)

All PENTA valves WSS model are tested to verify their BUBBLE TIGHTNESS (no visible leakage during hydraulic seat test according to ANSI B16.34 and during low pressure air seats test at 100 psi)

# VALVOLE WAFER SPLIT BODY A SFERA FLOTTANTE

## WAFER SPLIT BODY FLOATING BALL VALVES



-46 °C +400 °C

SSM

MATERIALI DISPONIBILI PER I SEGGI - AVAILABLE SEAT MATERIAL				
Codice Code	Materiale Material	Durezza Hardness	Temperature di lavoro Working temperature	Servizio Service Limits
<b>S01</b>	<b>SILVER PENTAFITE</b> (Nickel + Graphite )	120 HB	-100°C / +780°C (-148°F / +1436°F)	For clean services both liquid or gas. For use with <b>HTC, HTCN, HCR, WC, CRC, ST6</b> ball coated
<b>R01</b>	<b>RED PENTAFITE</b> (Cu + Graphite )	100 HB	-100°C / +500°C (-148°F / +932°F)	For clean services both liquid or gas. Lower friction factors in dry gas or steam service. For use with <b>HTC, HTCN, HCR, ST6</b> ball coated
<b>B01</b>	<b>BLACK PENTAFITE</b> (Carbon + Graphite )	80 HB	Amb. / +400°C (Amb. / +752°F)	For low pressure specific services where <b>S01</b> and <b>R01</b> cannot be used due to corrosion problems. A ball coat is not strictly necessary and should be evaluated time to time
<b>WC</b>	<b>CARBURO DI TUNGSTENO</b> <i>Tungsten Carbide Coat</i> (Detonation Gun/HVOF)	1100 HV	Amb. / +350°C ( Amb. / +662°F )	For liquid or gas services with high presence of solids. Not suitable when small presence of caustic soda is expected. For use with WC ball coat
<b>ST6</b>	<b>STELLITE Gr.6</b> (Detonation Gun/HVOF)	1000 HV	Amb. / +350°C ( Amb. / +662°F )	For liquid or gas services with small presence of solids. Suitable when small presence of caustic soda is expected. Best on dry gas or steam services. For use with <b>WC, CRC</b> ball coat
<b>CRC</b>	<b>CARBURO DI CROMO</b> <i>Chrome Carbide</i> (Detonation Gun)	800 HV	Amb. / +750°C ( Amb. / +1382°F )	For liquid or gas services with small presence of solids. Not suitable when small presence of caustic soda is expected.
<b>PK1</b>	<b>PEEK</b> (Polyetheretherketone)		-100°C. / +240°C (-148°F / +464°F)	For clean liquid or gas services with high frequency of valve operation.
<b>RPTFE</b>	<b>PTFE RINFORZATO VETRO/GARFITE</b> (Glass/Graphite reinforces PTFE)		-100°C/+220°C (-148°F/+428°F)	For clean liquid or gas services with high frequency of valve operation.

MATERIALI DISPONIBILI PER RIVESTIMENTO SFERE - AVAILABLE BALL COATING MATERIALS				
Codice Code	Materiale Material	Durezza Hardness	Temperature di lavoro Working temperature	Servizio Service Limits
<b>HTC</b>	<b>NITRURI DI TITANIO</b> <i>Titanium Nitride (PVD)</i>	2500 HV	-100°C / +600°C ( -148°F / +1112°F )	For clean services both liquid or gas. For gas and steam up to 180°C
<b>HTCN</b>	<b>CARBO-NITRURI DI TITANIO</b> <i>Carbo-Titanium Nitride (PVD)</i>	3500 HV	-100°C / +400°C ( -148°F / +752°F )	For liquid or gas services with small presence of solids. For gas and steam up to 180°C
<b>HCR</b>	<b>NITRURI DI CROMO</b> <i>Chrome- Nitride (PVD)</i>	3000 HV	Amb. / +750°C ( Amb. / +1382°F )	For clean services both liquid or gas. Best on oxidizing services
<b>WC</b>	<b>CARBURO DI TUNGSTENO</b> <i>Tungsten Carbide</i> (Detonation Gun/HVOF)	1100 HV	Amb. / +350°C ( Amb. / +662°F )	For liquid or gas services with high presence of solids. Not suitable when small presence of caustic soda is expected.
<b>CRC</b>	<b>CARBURO DI CROMO</b> <i>Chrome Carbide</i> (Detonation Gun/HVOF)	800 HV	Amb. / +750°C ( Amb. / +1382°F )	For liquid or gas services with small presence of solids. Not suitable when small presence of caustic soda is expected.
<b>ST6</b>	<b>STELLITE GR.6</b> (Detonation Gun/HVOF)	1000 HV	Amb. / +350°C ( Amb. / +662°F )	For liquid or gas services with small presence of solids. Suitable when small presence of caustic soda is expected. Best on dry or steam services.





Dimensionamenti ASME B16.34 / EN 12569 / API 608/ EN 17292 / ASME VIII DIV.1 / EN 12516-1

Estremità flangiate ASME B16.5 Cl. 150/300  
EN 1092-1 PN 10/16/25/40  
DIN 2632 / 2633 / 2634 / 2635

Collaudo ASME B16.104  
API 598  
EN 12266-1  
ISO 5208  
BS 6755-1

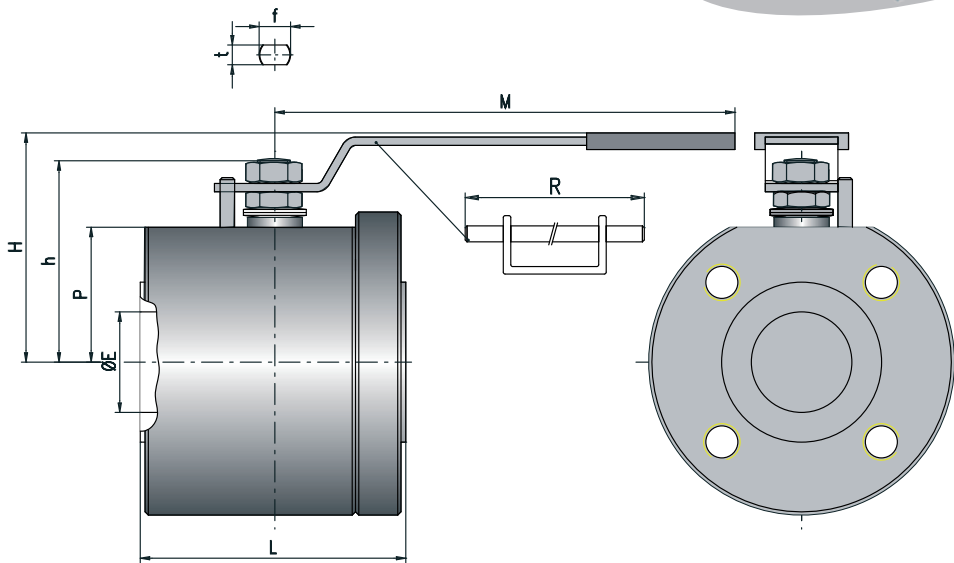

Dimensioni - outline dimensions

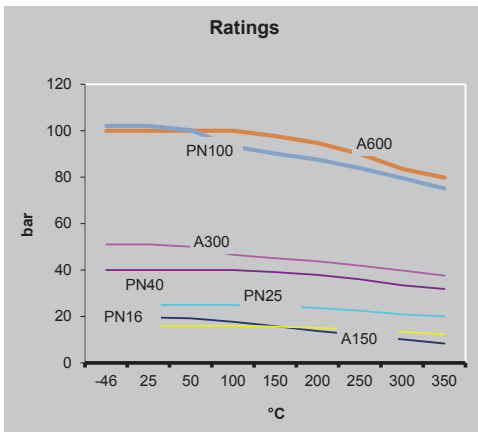

	DN 15	20	25	40	50	80	100	150
Ø"	1/2"	3/4"	1"	1 1/2"	2"	3"	4"	6"
ANSI 150 ØE	14	19	24	38	48	76	95	152
PN10-16 L	50	60	60	80	95	121	152	243
P	33	36	48	63	71	88	103	153
h	53	55	69	96	102	128	152	220
H	84	87	99	121	125	148	181	243
M	151	151	186	275	275	380		
R							500	800
f/t	10/6	10/6	12/8	16/10	16/10	22/14	30/18	45/30
ISO 5211	F03	F03	F03	F05	F05	F07	F10	F14

# VALVOLE WAFER SPLIT BODY A SFERA FLOTTANTE

## WAFER SPLIT BODY FLOATING BALL VALVES



-46 °C +400 °C

WSSM

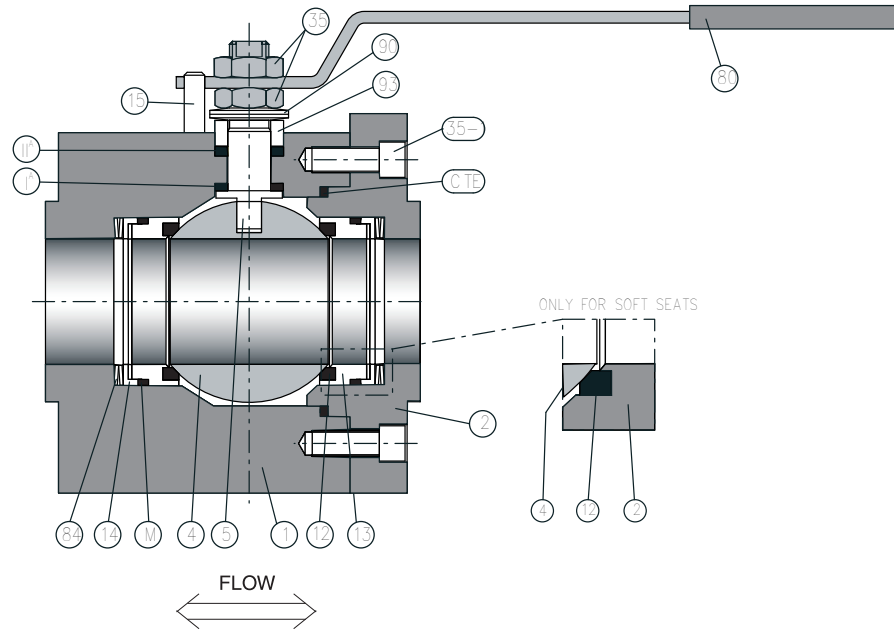

### Materiali base - base materials

CTE	Guarnizione Corpo / Terminale	Body / Connector Gasket	Grafoil
M	Guarnizione Retroseggio	Seat Gasket	Grafoil
II ^	Guarnizione Secondaria	Secondary Stem Seal	Grafoil
I ^	Guarnizione Primaria	Primary Stem Seal	Grafoil
93	Premi Baderna	Gland	316 s.s.
90	Molle Stelo	Stem Spring	301 s.s.
84	Molle Seggio	Seat Spring	301 s.s. / X750
80	Leva	Lever	Fe 37 UNI 7070
35-1	Bulloneria Corpo / Terminale	Body / Connector Bolts	304 s.s.
35	Dadi Stelo	Nut	304 s.s.
15	Fermo Leva	Lever Stopper	UNI 3740 Gr.8.8
14	Premigrafoil	Compression Ring	316 s.s.
13	Cassetto	Seat Holder	316 s.s.
12	Seggio	Seat Insert	PENTAFITE ST6 CRC- WC RPTFE
5	Stelo	Stem	A564 Tp.630 (17/4PH)
-	Rivestimento Sfera	Ball Coating	HCR/HTC ST6 WC/CRC
4	Sfera	Ball	316 s.s.
2	Terminale	Body Connector	A105 316 s.s.
1	Corpo	Body	A105 316 s.s.

**P. No. Parte - Part Name**

**Materiale - Material**

**Altre estremità disponibili su richiesta - Other end connections available on request**





penta s.r.l.

P40



MODELLO / MODEL

**P40**

**Fire-Safe**  
Certificate  
API 607 V ED.  
ISO 10497

**CRN**  
Certificate

**Ta-Luft**  
Approved  
(c/w 100 mm stem elongation)

**EAC**  
Eurasian Conformity

**CE**  
Directive 2014/68/UE  
"PED"

**Ex** II2G c IIC TX  
II2D c IIC TX  
Directive 2014/34/UE  
"ATEX"



**Il modello P40** utilizza la configurazione seggi della serie SAT per garantire la massima affidabilità e durata della tenuta della valvola con le alte pressioni. La tenuta stelo deriva dalla versione semplificata impiegata nella serie AP per semplificare le attività di manutenzione. Come in tutti i prodotti Penta sono disponibili anche per la serie P40 le sedi in PENTAFITE così come quelle ottenute tramite riporti duri. Tutte le valvole sono predisposte con foratura ISO 5211 per il montaggio attuatori.

**The P40 model** uses the SAT serie unique seat design to guarantee the best reliability and long-term tightness against high pressures. Stem seal is coming from the simplified version used in the AP serie to simplify maintenance activities. As like as all Penta production PENTAFITE seats are available on P40 together with hard coated ones. All valves are provided with ISO 5211 top drilling.

### Tenuta stelo

Il sistema a doppia molla e dadi di serraggio consente di fornire il corretto precarico alle tenute stelo, di recuperare usure e differenziali di dilatazione tra stelo e corpo.

### Stem tightness

The double spring system with loading nuts, allows the correct stem gasket pre-loading and the adjustment to recuperate wearing and clearance for different thermal dilation between stem and body.

### Stelo

Gli steli sono 100% sovradimensionati rispetto alla coppia attesa al max. DP di rating.

### Stem

Stem are 100% oversized against expected torque at max. rated DP.

### Sfera

Sfere rettificate ad alta precisione sono prodotte internamente e quindi indurite superficialmente con riporti a tecnologia avanzata.

### Ball

Very high precision grounded balls are produced inside and then hard coated with most advanced system.

### Guarnizioni

Sono utilizzate esclusivamente guarnizioni in Grafoil® resistenti alle alte temperature; nessun materiale polimerico è impiegato.

### Gasket

Only Grafoil® gaskets are used, inherently resistant to high temperatures; no polymers are used.

### Seggi

Entrambi i seggi metallici sono prevaricati con molle per una perfetta tenuta alle basse pressioni, per recuperare l'usura e le diverse dilatazioni termiche tra i diversi componenti.

La configurazione dei seggi garantisce lo scarico automatico delle sovrappressioni nel corpo.

### Seats

Both the two metallic seats are pre-loaded with springs in order to meet perfect low-pressure tightness and to compensate life wearing and different thermal expansions between internals. The seat design allows the automatic body cavity pressure relief.

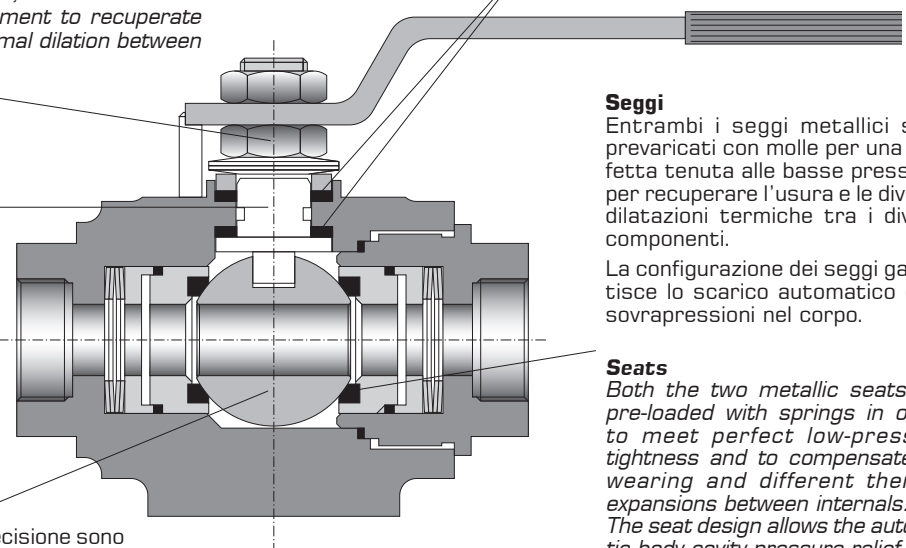

### INTERVALLO DI PRODUZIONE PRODUCTION RANGE

		CLASSI - PRESSURE CLASSES			
ANSI B 16.34		900		1500	
PN		160		250	
		F	T	F	T
DN	Modelli Models	P40		P40	
	1/2"				
	3/4"				
	1"				

F = Sfera flottante - Floating ball

Sfera vincolata - Trunnion mounted ball

# VALVOLE A SFERA FLOTTANTE A SEGGI METALLICI

## METAL SEATED FLOATING BALL VALVES



BI-DIRECTIONAL

MATERIALI DISPONIBILI PER I SEGGI - AVAILABLE SEAT MATERIALS				
Codice Code	Materiale Material	Durezza Hardness	Temperature di lavoro Working temperature	Servizio Service Limits
<b>S01</b>	<b>SILVER PENTAFITE</b> (Nickel + Graphite )	120 HB	-100°C / +780°C (-148°F / +1436°F)	For clean services both liquid or gas. For use with <b>HTC, HTCN, HCR, WC, CRC, ST6</b> ball coated
<b>R01</b>	<b>RED PENTAFITE</b> (Cu + Graphite )	100 HB	-100°C / +500°C (-148°F / +932°F)	For clean services both liquid or gas. Lower friction factors in dry gas or steam service. For use with <b>HTC, HTCN, HCR, ST6</b> ball coated
<b>WC</b>	<b>CARBURO DI TUNGSTENO</b> <i>Tungsten Carbide Coat</i> (Detonation Gun/HVOF)	1100 HV	Amb. / +350°C ( Amb. / +662°F )	For liquid or gas services with high presence of solids. Not suitable when small presence of caustic soda is expected. For use with WC ball coat
<b>ST6</b>	<b>STELLITE Gr.6</b> (Detonation Gun/HVOF)	1000 HV	Amb. / +350°C ( Amb. / +662°F )	For liquid or gas services with small presence of solids. Suitable when small presence of caustic soda is expected. Best on dry gas or steam services. For use with <b>WC, CRC</b> ball coat

MATERIALI DISPONIBILI PER RIVESTIMENTO SFERE - AVAILABLE BALL COATING MATERIALS				
Codice Code	Materiale Material	Durezza Hardness	Temperature di lavoro Working temperature	Servizio Service Limits
<b>HTC</b>	<b>NITRURI DI TITANIO</b> <i>Titanium Nitride (PVD)</i>	2500 HV	-100°C / +600°C ( -148°F / +1112°F )	For clean services both liquid or gas. For gas and steam up to 180°C
<b>HTCN</b>	<b>CARBO-NITRURI DI TITANIO</b> <i>Carbo-Titanium Nitride (PVD)</i>	3500 HV	-100°C / +400°C ( -148°F / +752°F )	For liquid or gas services with small presence of solids. For gas and steam up to 180°C
<b>HCR</b>	<b>NITRURI DI CROMO</b> <i>Chrome- Nitride (PVD)</i>	3000 HV	Amb. / +750°C ( Amb. / +1382°F )	For clean services both liquid or gas. Best on oxidizing services
<b>WC</b>	<b>CARBURO DI TUNGSTENO</b> <i>Tungsten Carbide</i> (Detonation Gun/HVOF)	1100 HV	Amb. / +350°C ( Amb. / +662°F )	For liquid or gas services with high presence of solids. Not suitable when small presence of caustic soda is expected.
<b>CRC</b>	<b>CARBURO DI CROMO</b> <i>Chrome Carbide</i> (Detonation Gun/HVOF)	800 HV	Amb. / +750°C ( Amb. / +1382°F )	For liquid or gas services with small presence of solids. Not suitable when small presence of caustic soda is expected.
<b>ST6</b>	<b>STELLITE GR.6</b> (Detonation Gun/HVOF)	1000 HV	Amb. / +350°C ( Amb. / +662°F )	For liquid or gas services with small presence of solids. Suitable when small presence of caustic soda is expected. Best on dry or steam services.

### GRADO DI TENUTA - TIGHTNESS

Tutte le valvole PENTA modello P40 sono collaudate per verificarne la TENUTA PERFETTA (perdita zero alla prova idraulica dei seggi secondo ANSI B16.34 e a 6 bar con aria).

All PENTA valves P40 model are tested to verify their BUBBLE TIGHTNESS (no visible leakage during hydraulic seat test according to ANSI B 16.34 and during low pressure air seats test at 100 psi)



Dimensionamenti  
*Design* ASME B16.34/API 608 CL. 900/1500  
EN 12516-1

Estremità flangiate  
*Flanged ends* NPT ASME B1.20.1  
SW ASME B16.11  
BW ASME B16.25  
(CON NIPPLI INTEGRALI  
C/W INTEGRAL NIPPLES)

Collaudo  
*Testing* ASME B16.104  
API 598  
EN 12266-I  
ISO 5208  
BS 6755-I

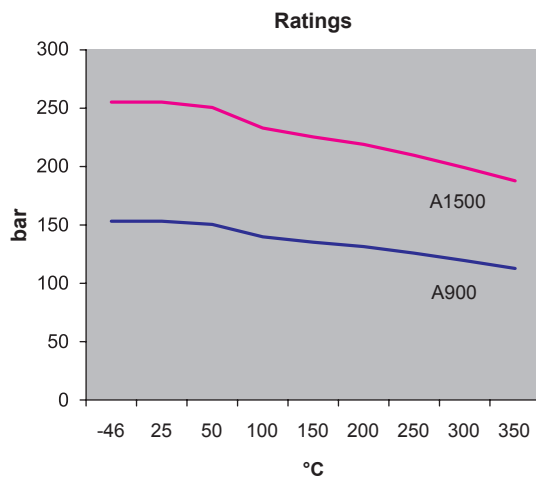
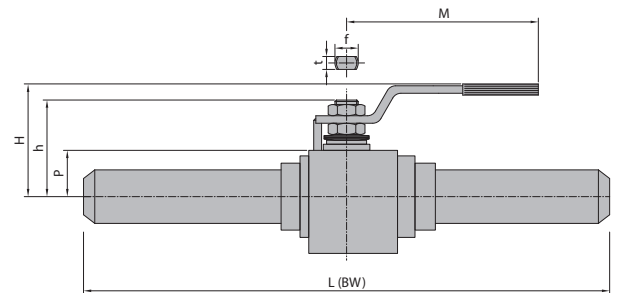
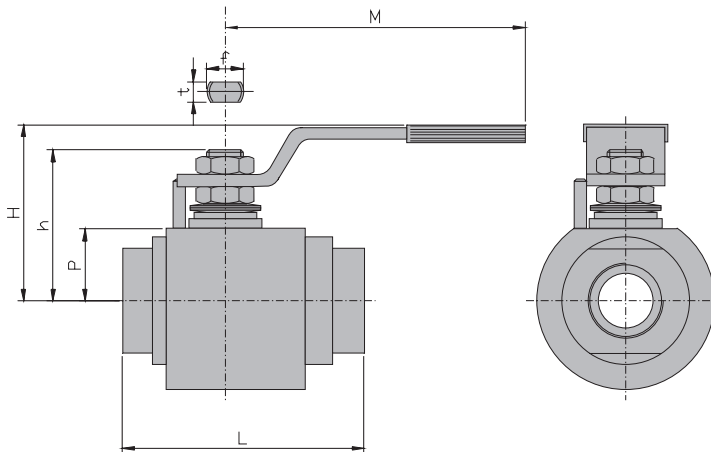

### Dimensioni - *outline dimensions*

DN	15	20	25
Ø"	1/2"	3/4"	1"
ØE	13	17	22
L	130	130	160
LBW	270	270	305
h	64	68	86
P	34	34	41
H	92	96	102
F/t	16/10	16/10	22/14
ISO 5211	F05	F05	F07



# VALVOLE A SFERA FLOTTANTE A SEGGI METALLICI

## METAL SEATED FLOATING BALL VALVES



BI-DIRECTIONAL

-100 °C +400 °C

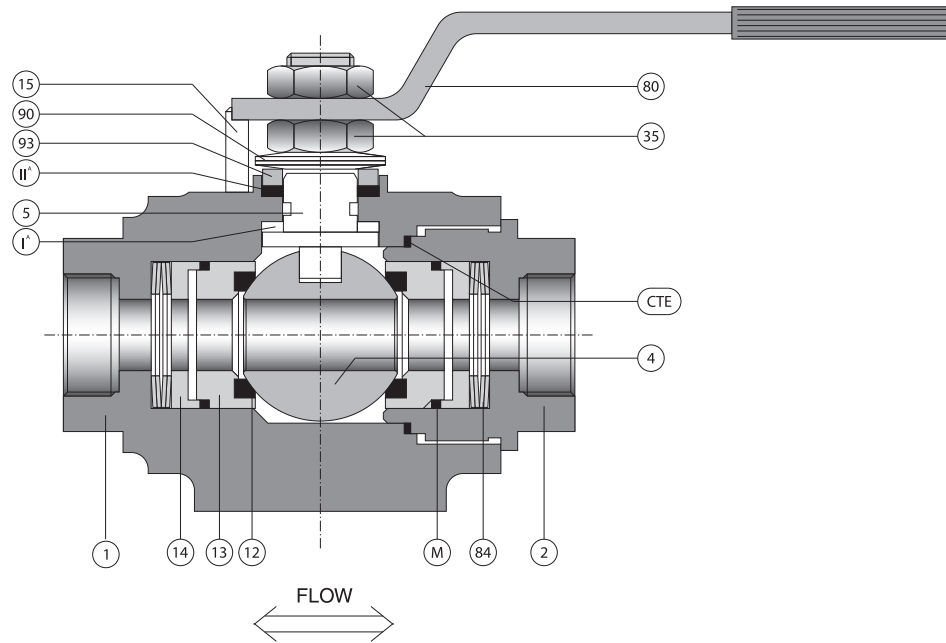

### Materiali base - base materials

CTE	Guarn. Corpo/Terminale	<i>Body connector gasket</i>	Grafoil	Grafoil
M	Guarn. Retroseggio	<i>Backseat gasket</i>	Grafoil	Grafoil
II <sup>A</sup>	Guarnizione Secondaria	<i>Secondary Stem seal</i>	Grafoil	Grafoil
I <sup>A</sup>	Guarnizione Primaria	<i>Primary stem seal</i>	Grafoil	Grafoil
93	Premi Baderna	<i>Gland</i>	304 S.S	304 S.S
90	Molle Stelo	<i>Stem spring</i>	UNS S30100	UNS S30100
84	Molle Seggio	<i>Seat spring</i>	UNS S30100	UNS S30100
80	Leva	<i>Handle</i>	Fe37 UNI 7070	Fe37 UNI 7070
35	Dadi Stelo	<i>Nut</i>	304 S.S.	304 S.S.
15	Fermo Leva	<i>Lever stopper</i>	Gr. 8.8 UNI 3740	Gr. 8.8 UNI 3740
14	Premigrafoil	<i>Compression ring</i>	A479 Tp.316	A479 Tp.316
13	Cassetto	<i>Body seat holder</i>	A479 Tp.316	A479 Tp.316
12	Seggio	<i>Seat</i>	PENTAFITE ST6 WC/CRC	PENTAFITE ST6 WC/CRC
5	Stelo	<i>Stem</i>	13% Cr. A564 Tp.630 (17/4PH)	A564 Tp.630 (17/4PH)
-	Riporto Sfera	<i>Ball coating</i>	HTC/HCR ST6 WC/CRC	HTC/HCR ST6 WC/CRC
4	Sfera	<i>Ball</i>	A479 Tp.316	A479 Tp.316
2	Terminale	<i>Connector</i>	A105	A479 Tp.304
1	Corpo	<i>Body</i>	A105	A479 Tp.304

**P. No. Parte - Part Name**

**Materiale - Material**

**Altri materiali disponibili su richiesta - Other materials are available on request**

**Altre estremità disponibili su richiesta - Other end connections available on request**

HTC = Nitruri di Titanio (*Titanium Nitrides*); HCR = Nitruri di Cromo (*Chrome Nitrides*); ST6 = Stellite 6 *Detonation Gun/HVOF*  
WC = Carburi di Tungsteno (*Tungsten Carbides Detonation Gun/HVOF*); CRC = Carburi di Cromo (*Chrome Carbides Detonation Gun/HVOF*)



## Accessori P40 P40 accessories

Leva prolunga SIP per linee coibentate  
*SIP lever elongation for insulated piping systems*

---



Riduttore - *Manual gear*

---

Prolunga stelo - *Stem elongation*

---



Attuatori pneumatici semplice o doppio effetto  
*Single or double acting actuators*

---

Attuatori Elettrici e Idrraulici  
Electric and Hydraulic Actuators



**penta s.r.l.**

**SAT**



**MODELLO / MODEL**

**SAT**

**Fire-Safe**  
Certificate  
API 607 V ED.  
ISO 10497

**CRN**  
Certificate

**Ta-Luft**  
Approved

**EAC**  
Eurasian Conformity

**CE**  
Directive 2014/68/UE  
"PED"

**Ex** II2G c IIC TX  
II2D c IIC TX  
Directive 2014/34/UE  
"ATEX"



**Il modello SAT** è la tipologia costruttiva PENTA che meglio si adatta al più ampio spettro di impieghi. La filosofia progettuale ha avuto come primo obiettivo il raggiungimento della massima affidabilità, mediante la realizzazione di soluzioni tecniche che ancora oggi non trovano riscontro sul mercato

Come tutta la produzione PENTA le valvole serie SAT sono progettate per essere equipaggiate con seggi metallici in PENTAFITE permettendo la realizzazione di valvole a seggi metallici con PERDITA ZERO per servizi con temperature di esercizio continuo fino a 780°C (1436°F) o pressioni fino a 720 bar.

Le caratteristiche elasto-plastiche della PENTAFITE e la costruzione interamente bullonata permettono facili interventi di manutenzione, non necessitando di lavoro di adattamento tra sedi di ricambio e sfere.

Sono inoltre disponibili sedi con riporto superficiale in materiali duri.

Le valvole SAT sono disponibili con sfera flottante o con sfera Trunnion mounted, con passaggio ridotto o passaggio pieno e sono tutte provviste di scarico automatico delle sovrapressioni nelle cavità del corpo.

**The SAT model** is the best design of PENTA to solve the widest range of uses. The main aim in its design philosophy is to achieve the highest reliability using advanced solutions that still has no equal on the market.

Like all PENTA production, SAT valves are equipped with metallic seats in PENTAFITE to allow the manufacturing of metal seated ball valves with absolutely ZERO LEAKAGE suitable for a wide range of services with working temperatures up to 780°C (1436°F) in continuous operation or 720 barg pressure.

The typical elastic properties of PENTAFITE seats and the fully bolted construction allow an easy maintenance without necessity of additional lapping of the seats against the ball.

Hard coated seats are also available.

SAT valves are available with floating or Trunnion mounted ball, with reduced bore or full bore and all valves are provided with automatic body cavity pressure relief arrangement.

Dimensionamenti <i>Design</i>	ANSI B16.34 / API 608 / API 6D / ISO 14313 / EN12569 / EN17292 ASME VIII Div. 1 / EN 12516-1
Estremità* <i>Valve Ends</i>	Flangiate ANSI B16.5 / EN 1092-1 / DIN <i>Flanged</i> A saldare ANSI B16.5 <i>Butt weld</i>
Collaudo <i>Testing</i>	ANSI B16.104 API 598 EN 12266-1 ISO 5208 BS 6755-1

\* Altre estremità disponibili a richiesta.  
*Other end connections are available on request.*

# VALVOLE A SFERA A SEGGI METALLICI METAL SEATED BALL VALVES



## PRINCIPALI CARATTERISTICHE - MAIN FEATURES

### Tenuta stelo

Tenuta stelo di progetto unico (brevettato). La molla posta all'estremità superiore dello stelo fornisce il precarico per la tenuta alle basse pressioni, recupera usura e giochi dovuti a dilatazioni differenziali tra stelo e coperchio.

### Stem tightness

*Unique stem seal design (patented). The spring placed at stem top gives the contact load for low pressure tightness and the adjustment for wearing and clearance for different dilatation between stem and cover.*

### Stelo

Gli steli sono 100% sovradimensionati rispetto alla coppia attesa al max. DP di rating.

### Stem

*Stem are 100% oversized against expected torque at max. rated DP.*

### Sfera

Sfere rettificate ad alta precisione sono prodotte internamente e quindi indurite superficialmente con riporti a tecnologia avanzata.

### Ball

*Very high precision ground balls are produced inside and then hard coated with most advanced system.*

### Coperchio superiore

Tutte le valvole SAT sono dotate di un coperchio superiore bullonato per una rapida sostituzione del gruppo stelo/guarnizioni.

### Upper cover

*All SAT valves are provided with bolted upper cover for quick and easy stem assembly maintenance.*

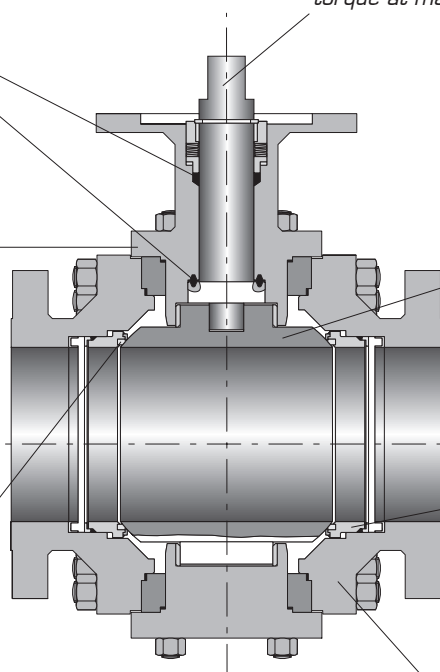

### Guarnizioni retroseggio

La guarnizione retroseggio in Grafoil ha una sezione brevettata che permette lo scarico automatico della pressione all'interno del corpo valvola.

### Backseat gasket

*The patented cross-section of the backseat Grafoil gasket allows the automatic body cavity relief.*

### Seggi

Le sedi metalliche sono precaricate con molle in entrambi i lati della valvola, anche nella versione flottante, per una completa bi-direzionalità.

### Seats

*Metallic seats are loaded with springs on both valve side, also for floating ball construction, for a full bi-directionality.*

### Flange - Bulloneria

Tutti gli accoppiamenti flangiati sono dimensionati secondo ASME VIII Div. 1.

### Bolting and Flanges

*All flanges connections are designed according to ASME VIII Div. 1*



<b>MATERIALI DISPONIBILI PER I SEGGI - AVAILABLE SEAT MATERIALS</b>				
Codice <i>Code</i>	Materiale <i>Material</i>	Durezza <i>Hardness</i>	Temperature di lavoro <i>Working temperature</i>	Servizio <i>Service limits</i>
<b>RPTFE</b>	<b>PTFE RINFORZATO VETRO/GRAFITE</b> (Glass/Graphite reinforces PTFE)		-100°C/+220°C (-148°F/+428°F)	For clean liquid or gas services with high frequency of valve operation.
<b>SO1</b>	<b>SILVER PENTAFITE</b> (Nickel + Graphite )		120 HB-100°C / +780°C ( -148°F / +1436°F )	For clean services both liquid or gas. For use with <b>HTC, HTCN, HCR, WC, CRC, ST6</b> ball coated
<b>RO1</b>	<b>RED PENTAFITE</b> (Cu + Graphite )	100 HB	-100°C / +500°C ( -148°F / +932°F )	For clean services both liquid or gas. Lower friction factors in dry gas or steam service. For use with <b>HTC, HTCN, HCR, ST6</b> ball coated
<b>BO1</b>	<b>BLACK PENTAFITE</b> (Carbon + Graphite )	80 HB	Amb. / +400°C ( Amb. / +752°F )	For low pressure specific services where <b>SO1</b> and <b>RO1</b> cannot be used due to corrosion problems. A ball coat is not strictly necessary and should be evaluated time to time
<b>WC</b>	<b>CARBURO DI TUNGSTENO</b> <i>Tungsten Carbide Coat</i> (Detonation Gun/HVDF)	1100 HV	Amb. / +350°C ( Amb. / +662°F )	For liquid or gas services with high presence of solids. Not suitable when small presence of caustic soda is expected. For use with <b>WC</b> ball coat
<b>CRC</b>	<b>CARBURO DI CROMO</b> <i>Chrome Carbide</i> (Detonation Gun)	800 HV	Amb. / +750°C ( Amb. / +1382°F )	For liquid or gas services with small presence of solids. Not suitable when small presence of caustic soda is expected.
<b>ST6</b>	<b>STELLITE Gr.6</b> (Detonation Gun/HVDF)	1000 HV	Amb. / +350°C ( Amb. / +662°F )	For liquid or gas services with small presence of solids. Suitable when small presence of caustic soda is expected. Best on dry gas or steam services. For use with <b>WC, CRC</b> ball coat

<b>MATERIALI DISPONIBILI PER RIVESTIMENTO SFERE - AVAILABLE COATING BALL MATERIALS</b>				
Codice <i>Code</i>	Materiale <i>Material</i>	Durezza <i>Hardness</i>	Temperature di lavoro <i>Working temperature</i>	Servizio <i>Service limits</i>
<b>HTC</b>	<b>NITRURI DI TITANIO</b> <i>Titanium Nitride</i> (PVD)	2500 HV	-100°C / +600°C ( -148°F / +1112°F )	For clean services both liquid or gas. For gas and steam up to 180°C
<b>HTCN</b> (PVD)	<b>CARBO-NITRURI DI TITANIO</b> Carbo-Titanium Nitride	3500 HV	-100°C / +400°C ( -148°F / +752°F )	For liquid or gas services with small presence of solids. For gas and steam up to 180°C
<b>HCR</b>	<b>NITRURI DI CROMO</b> Chrome- Nitride (PVD)	3000 HV	Amb. / +750°C ( Amb. / +1382°F )	For clean services both liquid or gas. Best on oxidizing services
<b>WC</b>	<b>CARBURO DI TUNGSTENO</b> Tungsten Carbide (Detonation Gun/HVDF)	1100 HV	Amb. / +350°C ( Amb. / +662°F )	For liquid or gas services with high presence of solids. Not suitable when small presence of caustic soda is expected
<b>CRC</b>	<b>CARBURO DI CROMO</b> Chrome Carbide (Detonation Gun/HVDF)	800 HV	Amb. / +750°C ( Amb. / +1382°F )	For liquid or gas services with small presence of solids. Not suitable when small presence of caustic soda is expected.
<b>ST6</b>	<b>STELLITE GR.6</b> (Detonation Gun/HVDF)	1000 HV	Amb. / +350°C ( Amb. / +662°F )	For liquid or gas services with small presence of solids. Suitable when small presence of caustic soda is expected. Best on dry or steam services.

# VALVOLE A SFERA A SEGGI METALLICI METAL SEATED BALL VALVES



## GRADO DI TENUTA - TIGHTNESS

Tutte le valvole PENTA modello SAT sono collaudate per verificarne la TENUTA PERFETTA (perdita zero alla prova idraulica dei seggi secondo ANSI B16.34 e a 6 bar con aria).

All PENTA valves SAT model are tested to verify their BUBBLE TIGHTNESS ( no visible leakage during hydraulic seat test according to ANSI B 16.34 and during low pressure air seats test at 100 psi).

## INTERVALLO DI PRODUZIONE - PRODUCTION RANGE

### CLASSI - PRESSURE CLASSES

ANSI B 16.34	150		300		600		900		1500		2500	
	PN		40 - 50		64 - 100		150		250		420	
Diametri Nominali Nominal diameter	F	T	F	T	F	T	F	T	F	T	F	T
1/2"												
3/4"												
1"												
1 1/2"												
2"												
3"												
4"												
6"												
8"												
10"												
12"												
14"												
16"												
18"												
20"												
22"												
24"												
26"												
28"												
30"												
32"												

F = Sfera flottante - Floating ball

T = Sfera vincolata - Trunnion mounted ball

## ACCESSORI DISPONIBILI - AVAILABLE ACCESSORIES

Diversi accessori sono disponibili a richiesta  
Many accessories are available on request

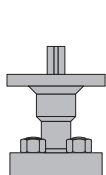

Coperchio con flangia o leva  
Cover with flange or lever

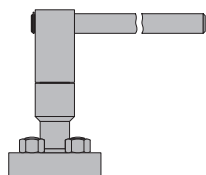

Coperchio allungato per alta temperatura  
Elongated cover for high temperatures

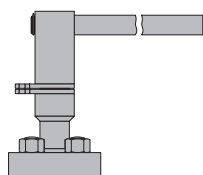
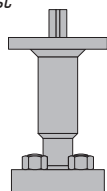

locking device

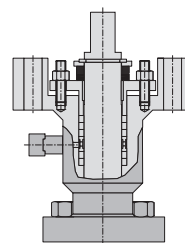

Coperchio con baiderna  
Cover with packing

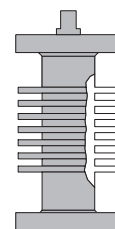

Coperchio alettato  
Finned cover

## OPERATORI DISPONIBILI - AVAILABLE OPERATORS

- Riduttori manuali

- Manual gears

- Attuatori pneumatici a semplice o doppio effetto

- Single or double acting pneumatic actuators

- Attuatori elettrici

- Electric actuator

- Attuatori idraulici

- Hydraulic actuators





# SAT

-100 °C +720 °C

## Materiali base - base materials

TE	Guarnizione Corpo / Cap. Inf.	Lower Cover Gasket	Grafoil	
CCE	Guarnizione Corpo / Cap. Sup.	Upper Cover Gasket	Grafoil	
CTE	Guarnizione Corpo / Terminale	Body / Connector Gasket	Grafoil	
M	Guarnizione Retroseggio	Seat Gasket	Grafoil	
Il^	Guarnizione Secondaria	Secondary Stem Seal	Grafoil	
I^	Guarnizione Primaria	Primary Stem Seal	Grafoil	
94	Bussola Strisciamento Stelo	Stem Plain Bearing	DU	
93	Premi Baderna	Gland	316 s.s.	
92	Anello D'arresto Stelo	Stem Retaining Ring	316 s.s.	
90	Molle Stelo	Stem Spring	301 s.s.	
84	Molle Seggio	Seat Spring	301 s.s. / X750	
61	Supporto Seggio	Seat Support	316 s.s.	
53	Manicotto	Coupling	316 s.s.	
43	Bussola Strisciamento Manicotto	Stem Gland	DU / BM	
35-3	Bulloneria Corpo / Cap. Inf.	Lower Cover Bolts	B7/2H	B8/Gr:8
35-2	Bulloneria Corpo / Cap. Sup.	Upper Cover Bolts	B7/2H	B8/Gr:8
35-1	Bulloneria Corpo / Terminale	Body / Connector Bolts	B7/2H	B8/Gr:8
31	Rondella Premi Molla	Stem Spring Compression Ring	316 s.s.	
22	Piastra Supporto Sfera	Saddle	A105	316 s.s.
21	Bussola Strisciamento Trunn.	Trunnion Plain Bearing	DU / BM	
14	Premigrafoil	Compression Ring	316 s.s.	
13	Cassetto	Seat Holder	316 s.s.	
12	Seggio	Seat Insert	PENTAFITE ST6 CRC/WC	
7	Coperchio Inf.	Lower Cover	A105	316 s.s.
6	Coperchio Sup.	Upper Cover	A105	316 s.s.
5	Stelo	Stem	410 s.s.	316 s.s.
-	Rivestimento Sfera	Ball Coating	HCR / HTC ST6 WC / CRC	
4	Sfera	Ball	316 s.s.	
2	Terminale	Body Connector	A105	316 s.s.
1	Corpo	Body	A105	316 s.s.

P.No. Parte - Part name

Materiale - Material

## Tipica Valvola SAT Trunnion Typical SAT with Trunnion mounted ball

Costruzione/version "A"

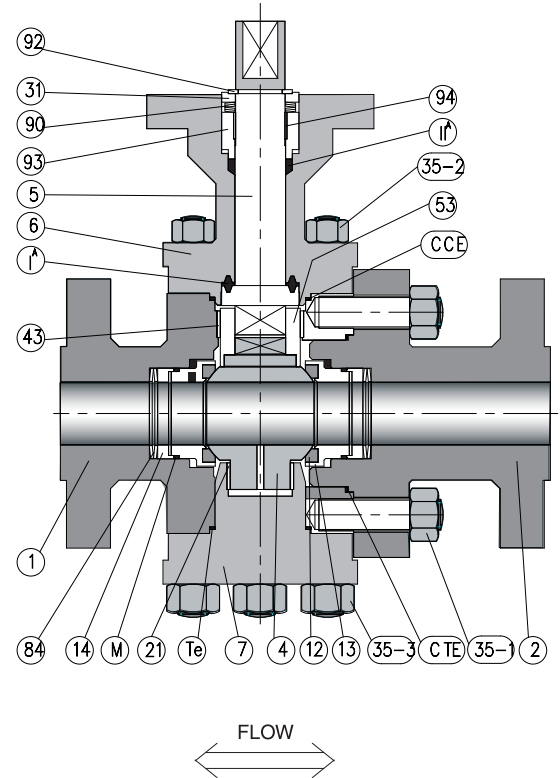

Costruzione/version "B"

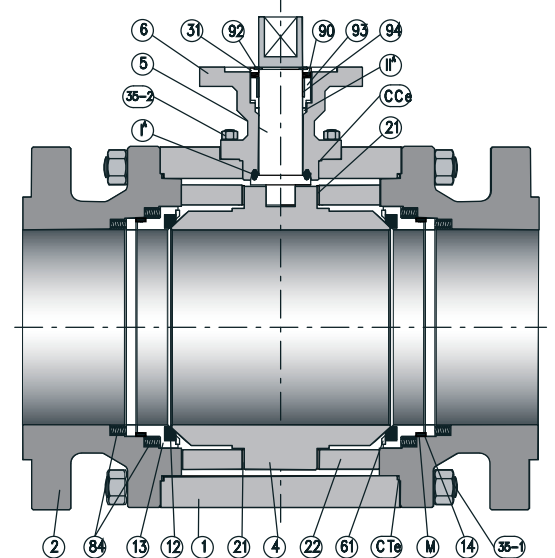

Le valvole possono essere realizzate in qualsiasi materiale in accordo ai requisiti del Committente purchè in barre, barre o anelli fucinati e forgiati  
Valves can be manufactured in all materials according Customer requirements when available in form of bars, forged bars or rings

# VALVOLE A SFERA A SEGGI METALLICI

## METAL SEATED BALL VALVES



-100 °C +720 °C

### Materiali base - base materials

CCE	Upper cover gasket	Grafoil	Grafoil
CTE	Body-Connector gasket	Grafoil	Grafoil
M	Seat gasket	Grafoil	Grafoil
II <sup>A</sup>	Secondary stem seal	Grafoil	Grafoil
I <sup>A</sup>	Primary stem seal	Grafoil	Grafoil
94	Stem plain bearing	DU	DU
93	Gland	316 s.s.	316 s.s.
92	Stem retaining ring	316 s.s.	316 s.s.
90	Stem spring	AISI 301	AISI 301
84	Seat spring	AISI 301	X750
80	Handle	Fe37 UNI 7070	Fe37 UNI 7070
76	Distance	316 s.s.	316 s.s.
35-2	Upper cover Bolts	B7 / 2H	B8 / Gr.8
35-1	Body/Connector Bolts	B7 / 2H	B8 / Gr.8
31	Stem spring comp. ring	316 s.s.	316 s.s.
15	Wrench head	A105	316 s.s.
14	Compression ring	316 s.s.	316 s.s.
13	Seat holder	316 s.s.	316 s.s.
12	Seat insert	PENTAFITE ST6 WC/CRC	PENTAFITE ST6 WC/CRC
6	Upper cover	A105	316 s.s.
5	Stem	410 s.s.	316 s.s.
-	Ball coating	HTC/HCR ST6 WC/CRC	HTC/HCR ST6 WC/CRC
4	Ball	316 s.s.	316 s.s.
2	Body Connector	A105	316 s.s.
1	Body	A105	316 s.s.

**P. No. Parte - Part Name      Materiale - Material**

**Tipica Valvola SAT a sfera flottante**  
**Typical SAT with floating ball**

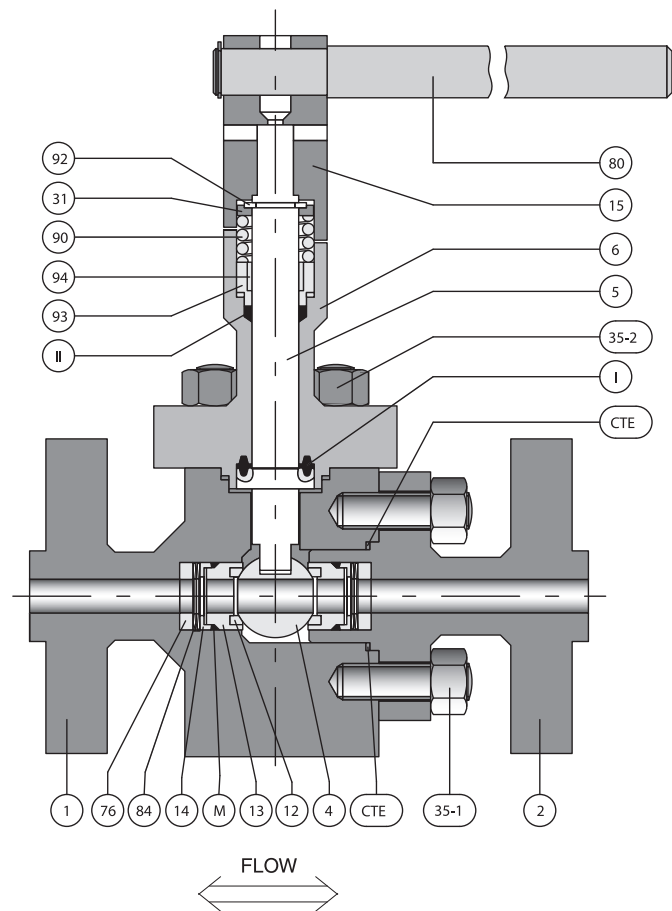

**Le valvole possono essere realizzate in qualsiasi materiale in accordo ai requisiti del Committente purchè in barre, barre o anelli fucinati e forgiati**  
**Valves can be manufactured in all materials according Customer requirements when available in form of bars, forged bars or rings**





**penta s.r.l.**

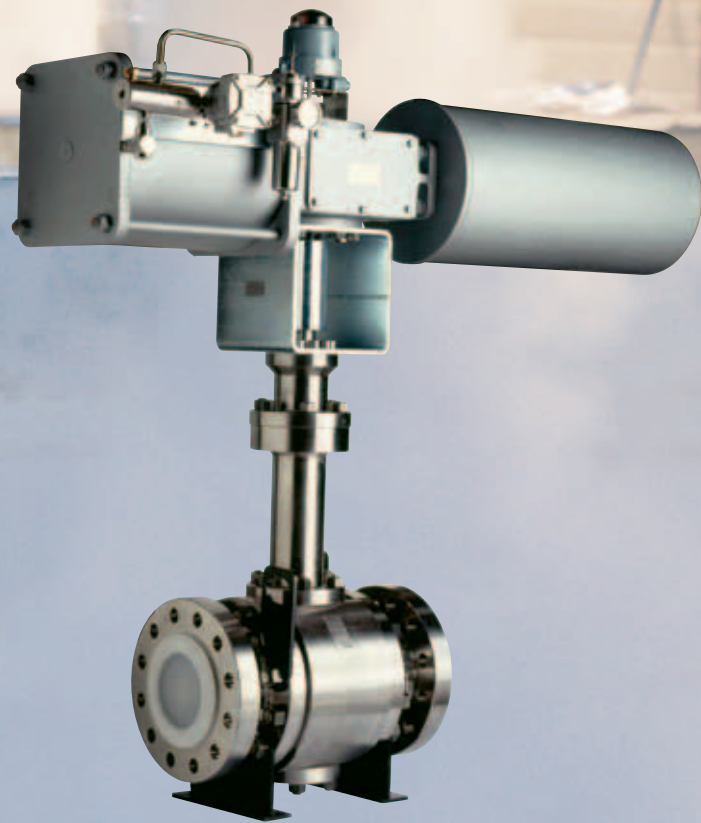

**SAT CRIO**

**MODELLO / MODEL**

**SAT CRIO**

**ABS**  
Approved

**Fire-Safe**  
Certificate  
API 607 V ED.  
ISO 10497

**CRN**  
Certificate

**Ta-Luft**  
Approved



Eurasian Conformity



Directive 2014/68/UE  
"PED"



**II2G c IIC TX**  
**II2D c IIC TX**  
Directive 2014/34/UE  
"ATEX"



**Il modello SAT** crio è l'evoluzione della costruzione SAT verso la bassa temperatura.

La filosofia progettuale contiene soluzioni tecniche uniche sul mercato, tutte tese al raggiungimento della massima affidabilità così come dimostrato dagli eccezionali risultati ottenuti con le innumerevoli applicazioni sul campo.

Come tutta la produzione PENTA le valvole serie SAT crio sono progettate per essere equipaggiate con seggi metallici in PENTAFITE (fino a  $-100^{\circ}\text{C}$ ) o in materiali polimerici per temperature inferiori, permettendo la realizzazione di valvole con PERDITA ZERO.

Le valvole SAT crio sono disponibili con sfera flottante o con sfera Trunnion mounted, con passaggio ridotto o passaggio pieno e sono tutte provviste di scarico automatico delle sovrappressioni nelle cavità del corpo oltre che di prolunga criogenica dello stelo di manovra.

**The SAT crio model** is the extension of the SAT model down to the low temperature.

The design philosophy involve unique technical solutions to meet the bet reliability as many field applications have demonstrated.

Like all PENTA production, SAT crio valves are equipped with metallic seats in PENTAFITE (down to  $-100^{\circ}\text{C}$  max.) or with polymeric seats for lower working temperature, resulting ball valves with absolutely ZERO LEAKAGE.

SAT crio valves are available with floating or Trunnion mounted ball, with reduced bore or full bore and all valves are provided with automatic body cavity pressure relief arrangement as like as cryogenic stem elongation.

Dimensionamenti <i>Design</i>	B16.34 / API 608 / BS 6364 / EN1626 ASME VIII Div.1 / EN 12516-1
----------------------------------	---

Estremità* <i>Valve ends</i>	flangiate ANSI B16.5 / EN 1092-1 / DIN <i>Flanged</i> A saldare ANSI B16.25 <i>Butt weld</i>
---------------------------------	---

Collaudo <i>Testing</i>	ANSI B16.104 / API 598 API 598 EN 12266-1 ISO 5208 BS 6755-1
----------------------------	--

\* Altre estremità disponibili a richiesta.  
*Other end connections are available on request.*



# VALVOLE A SFERA PER IMPIEGHI CRIOGENICI

## BALL VALVES FOR CRYOGENIC SERVICES



### PRINCIPALI CARATTERISTICHE - MAIN FEATURES

#### Tenuta stelo

Tenuta stelo di progetto unico (brevettato). La molla posta all'estremità superiore dello stelo fornisce il precarico per la tenuta alle basse pressioni, recupera usura e giochi dovuti a dilatazioni differenziali tra stelo e coperchio.

#### Stem tightness

*Unique stem seal design (patented). The spring placed at stem top gives the contact load for low pressure tightness and the adjustment for wearing and clearance for different dilatation between stem and cover.*

#### Prolunga Criogenia

Tutte le valvole sono dotate di prolunga stelo con cavità in comunicazione con il corpo valvola di lunghezza in accordo alle specifiche Shell SPE 77/100

#### Cryogenic Vapour Space

*All valves are provided with stem cryogenic elongation communicating with valve body cavities with length in accordance with SHELL SPE 77/100*

#### Seggi

I seggi metallici o polimerici sono precaricati con molle su entrambi i lati della valvola, anche nella versione a sfera flottante, per una completa bi-direzionalità e per lo scarico automatico delle sovrappressioni nel corpo.

#### Seats

*Metallic or polymeric seats are loaded with springs on both Valve sides, also in floating ball construction for a full Bi-directionality and automatic body cavities relief.*

#### Stelo

Gli steli sono 100% sovradimensionati rispetto alla coppia attesa al max. DP di rating.

#### Stem

*Stem are 100% oversized against expected torque at max. rated DP.*

#### Sfera

Sfere rettificate ad alta precisione sono prodotte internamente e quindi indurite superficialmente con riporti a tecnologia avanzata.

#### Ball

*Very high precision grounded balls are produced inside and then hard coated with most advanced system.*

#### Guarnizioni retroseggio

La guarnizione retroseggio in Grafoil ha una sezione brevettata che permette lo scarico automatico della pressione all'interno del corpo valvola.

#### Backseat gasket

*The patented cross-section of the backseat Grafoil gasket allows the automatic body cavity relief.*

#### Guarnizioni

Tutte le guarnizioni sono realizzate in Grafite espansa per garantire la loro inalterabilità a qualsiasi temperatura

#### Gaskets

*All gaskets are made in Expanded Graphite for their Unalterability against any temperature conditions*

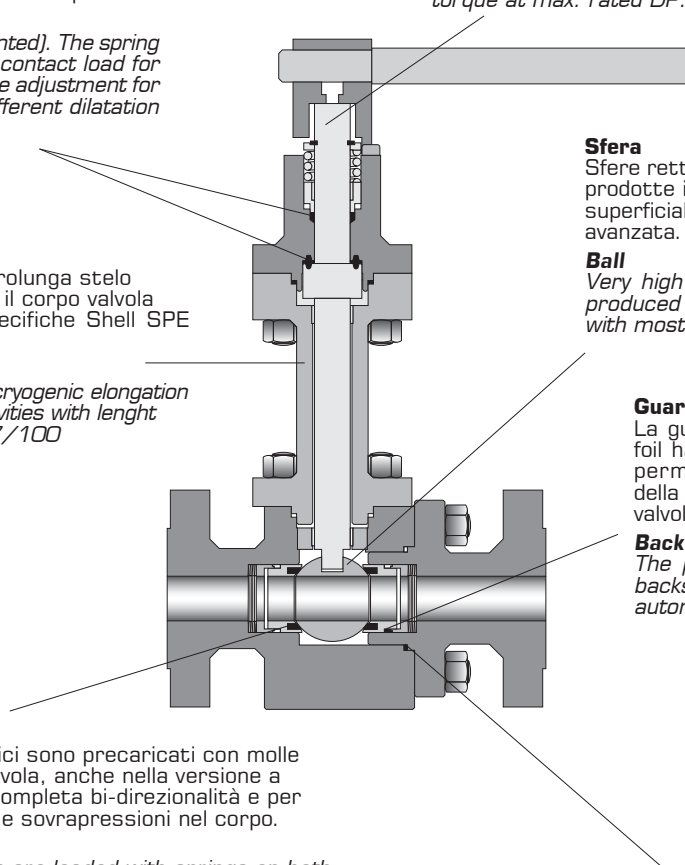



<b>MATERIALI DISPONIBILI PER I SEGGI - AVAILABLE SEAT MATERIALS</b>					
Codice <i>Code</i>	Materiale <i>Material</i>	Durezza <i>Hardness</i>	Temperature di lavoro <i>Working temperature</i>	Pressioni di lavoro <i>Working pressure</i>	Servizio <i>Service limits</i>
<b>KEL-F</b>	<b>KEL-F (PCTFE)</b>		-200°C / +150°C ( -328°F / +302°F )		For cryogenic services, all temperatures
<b>PTFE</b>	<b>PTFE</b>		-200°C / +200°C ( -328°F / +392°F )	ANSI 150 – 1500 PN 10 - 250	For cryogenic services, all temperatures.
<b>PEEK</b>	<b>PoliEter EterKetone</b>		-100°C / +240°C ( -148°F / +464°F )	ANSI 150 – 1500 PN 10 - 250	For cryogenic services, down to -100°C only, with high pressures
<b>S01</b>	<b>SILVER PENTAFITE</b> (Nickel + Graphite )	120 HB	-100°C / +780°C ( -148°F / +1436°F )	ANSI 150 – 600 PN 10 - 100	For cryogenic services, down to -100°C only

<b>MATERIALI DISPONIBILI PER RIVESTIMENTO SFERE - AVAILABLE COATING BALL MATERIALS</b>					
Codice <i>Code</i>	Materiale <i>Material</i>	Durezza <i>Hardness</i>	Temperature di lavoro <i>Working temperature</i>	Pressioni di lavoro <i>Working pressure</i>	Servizio <i>Service limits</i>
<b>HTC</b>	<b>NITRURI DI TITANIO</b> <i>Titanium Nitride</i> (PVD)	2500 HV	-200°C / +600°C ( -148°F / +1112°F )	ANSI 150 – 600 PN 10 - 100	For clean services both liquid or gas. For gas and steam up to 180°C
<b>HCR</b>	<b>NITRURI DI CROMO</b> <i>Chrome- Nitride</i> (PVD)	3000 HV	-100°C / +780°C ( -148°F / +1112°F )	ANSI 150 – 300 PN 10 - 100	For clean services both liquid or gas. Best on oxidizing services

## GRADO DI TENUTA - TIGHTNESS

Tutte le valvole PENTA modello SAT Crio sono collaudate per verificarne la TENUTA PERFETTA (perdita zero alla prova idraulica dei seggi secondo ANSI B16.34 e a 6 bar con aria).

All PENTA valves SAT Crio model are tested to verify their BUBBLE TIGHTNESS (no visible leakage during hydraulic seat test according to ANSI B 16.34 and during low pressure air seats test at 100 psi).

<b>PROLUNGA CRIOGENICA STELO - STEM CRYOGENIC ELONGATION</b>					
DN		15-25	40-50	80-100	150
Lunghezza prolunga Stelo (mm) <i>Stem Vapour lenght</i>		200	250	300	350

# VALVOLE A SFERA PER IMPIEGHI CRIOGENICI

## BALL VALVES FOR CRYOGENIC SERVICES



### INTERVALLO DI PRODUZIONE - PRODUCTION RANGE

CLASSI - PRESSURE CLASSES										
ANSI B 16.34	150		300		600		900		1500	
PN	16 - 25		40 - 50		64 - 100		150		250	
Diametri Nominali Nominal diameter	F	T	F	T	F	T	F	T	F	T
1/2"										
3/4"										
1"										
1 1/2"										
2"										
3"										
4"										
6"										
8"										
10"										

F = Sfera flottante - *Floating ball*

T = Sfera vincolata - *Trunnion mounted ball*

### ACCESSORI DISPONIBILI - AVAILABLE ACCESSORIES

Diversi accessori sono disponibili a richiesta  
*Many accessories are available on request*

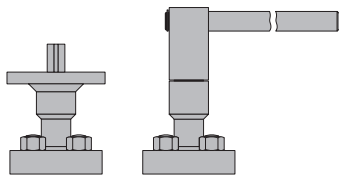

Coperchio con flangia o leva  
*Cover with flange or lever*

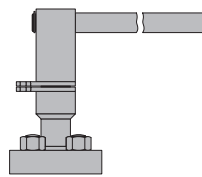

*locking device*

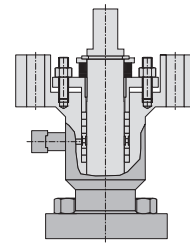

Coperchio con baderna  
*Cover with packing*

### OPERATORI DISPONIBILI - AVAILABLE OPERATORS

- Riduttori manuali
- Attuatori pneumatici a semplice o doppio effetto
- Attuatori elettrici
- Attuatori idraulici
- *Manual gears*
- *Single or double acting pneumatic actuators*
- *Electric actuator*
- *Hydraulic actuators*





## Materiali base - base materials

CCe	Body Cover gasket	Grafoil	Grafoil
CTe	Body Connector gasket	Grafoil	Grafoil
M	Backseat gasket	Grafoil	Grafoil
II <sup>A</sup>	Secondary Stem seal	Grafoil	Grafoil
I <sup>A</sup>	Primary stem seal	Grafoil	Grafoil
93	Gland	304 s.s.	304 s.s.
92	Stop Ring	304 s.s.	304 s.s.
90	Stem spring	UNS S30100	UNS S30100
84	Seat spring	UNS S30100	UNS S30100
80	Handle	Fe37 UNI 7070	Fe37 UNI 7070
46	Cryogenic Elongation	A479 Tp.304	A479 Tp.316
44	Lower Stem Bearing	DU	DU
43	Upper Stem Bearing	DU	DU
35-2	Cover Boltings	B8 / Gr.8	B8M / Gr.8M
35-1	Body Boltings	B8 / Gr.8	B8M / Gr.8M
31	Stem Spring Ring	304 s.s.	304 s.s.
15	Wrench	A479 Tp.304	A479 Tp.316
14	Compression ring	A479 Tp.316	A479 Tp.316
13	Seat holder	A479 Tp.316	A479 Tp.316
12	Seat	PENTAFITE PTFE PEEK KEL - F	PENTAFITE PTFE PEEK KEL - F
5	Stem	A479 Tp.316 Duplex s.s. UNS S31803	A479 Tp.316 Duplex s.s. UNS S31803
-	Ball coating	-- / HTC / HCR	-- / HTC / HCR
4	Ball	A479 Tp.316 Duplex s.s. UNS S31803	A479 Tp.316 Duplex s.s. UNS S31803
2	Connector	A479 Tp.304	A479 Tp.316
1	Body	A479 Tp.304	A479 Tp.316

**P. No.**    **Parte - Part Name**    **Materiale - Material**

## Tipica Valvola Crio Flottante Typical SAT Crio with Floating Ball

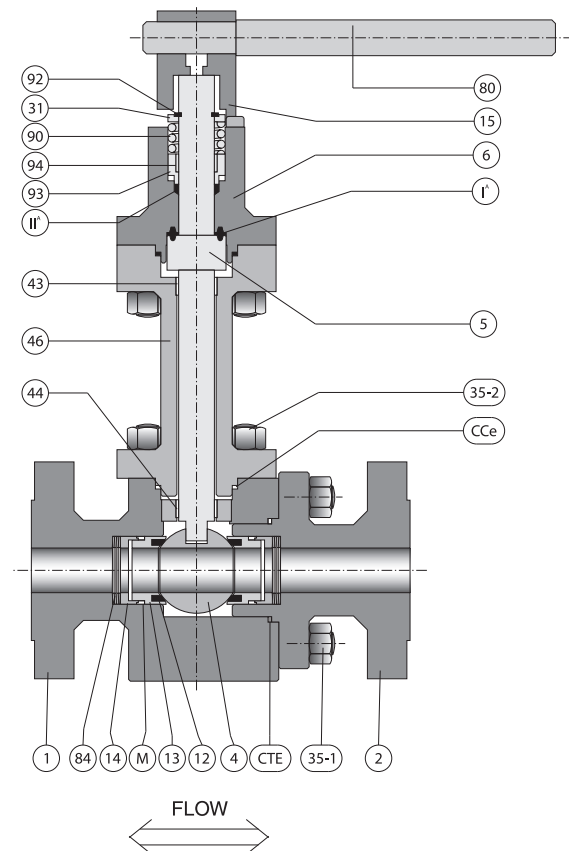

**Le valvole possono essere realizzate in qualsiasi materiale in accordo ai requisiti del Committente purchè in barre, barre o anelli fucinati e forgiati**  
*Valves can be manufactured in all materials according Customer requirements when available in form of bars, forged bars or rings*

# VALVOLE A SFERA PER IMPIEGHI CRIOGENICI

## BALL VALVES FOR CRYOGENIC SERVICES



-196 °C +200 °C

### Materiali base - base materials

Te	Body Cover gasket	Grafoil	Grafoil
CCe	Body Cover gasket	Grafoil	Grafoil
CTe	Body Connector gasket	Grafoil	Grafoil
M	Backseat gasket	Grafoil	Grafoil
IA	Secondary Stem seal	Grafoil	Grafoil
IA	Primary stem seal	Grafoil	Grafoil
93	Gland	304 s.s.	304 s.s.
92	Stop Ring	304 s.s.	304 s.s.
90	Stem spring	UNS S30100	UNS S30100
84	Seat spring	UNS S30100	UNS S30100
80	Handle	Fe37 UNI 7070	Fe37 UNI 7070
46	Cryogenic Elongation	A479 Tp.304	A479 Tp.316
44	Lower Stem Bearing	DU	DU
43	Upper Stem Bearing	DU	DU
35-3	Cover Boltings	B8 / Gr.8	B8M / Gr.8M
35-2	Cover Boltings	B8 / Gr.8	B8M / Gr.8M
35-1	Body Boltings	B8 / Gr.8	B8M / Gr.8M
31	Stem Spring Ring	304 s.s.	304 s.s.
21	Ball Bearings	DU	DU
15	Wrench	A479 Tp.304	A479 Tp.316
14	Compression ring	A479 Tp.316	A479 Tp.316
13	Seat holder	A479 Tp.316	A479 Tp.316
12	Seat	PENTAFITE PTFE PEEK KEL -F	PENTAFITE PTFE PEEK KEL -F
7	Lower Cover	A479 Tp.304	A479 Tp.316
5	Stem	A479 Tp.316 Duplex s.s. UNS S31803	A479 Tp.316 Duplex s.s. UNS S31803
-	Ball coating	-- / HTC / HCR	-- / HTC / HCR
4	Ball	A479 Tp.316 Duplex s.s. UNS S31803	A479 Tp.316 Duplex s.s. UNS S31803
2	Connector	A479 Tp.304	A479 Tp.316
1	Body	A479 Tp.304	A479 Tp.316

**P. No. Parte - Part Name      Materiale - Material**

**Tipica valvola SAT Crio Trunnion**  
**Typical SAT Crio with Trunnion Ball**

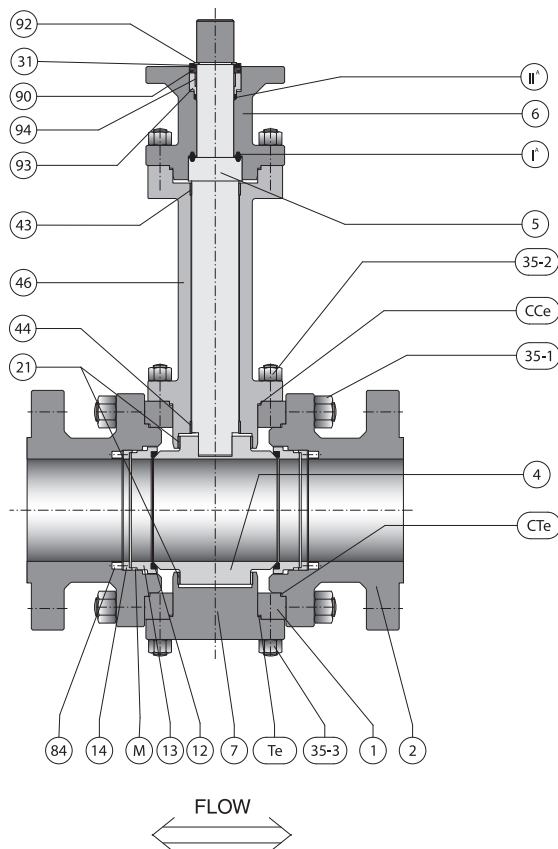

SAT CRIO

Le valvole possono essere realizzate in qualsiasi materiale in accordo ai requisiti del Committente purchè in barre, barre o anelli fucinati e forgiati  
Valves can be manufactured in all materials according Customer requirements when available in form of bars, forged bars or rings





SAT 3

MODELLO / MODEL

**SAT 3**



Eurasian Conformity



Directive 2014/68/UE  
"PED"



II2G c IIC TX  
II2D c IIC TX

Directive 2014/34/UE  
"ATEX"



**Il modello SAT3** è una evoluzione della tipologia costruttiva SAT1 mediante l'inserimento di due anelli (chiamati raschiatori) all'interno ed all'esterno dei seggi.

Gli anelli raschiatori hanno il compito di:

- pulire la superficie della sfera durante la manovra
- proteggere i seggi dalla azione abrasiva delle parti solide contenute nel fluido
- evitare l'incunearsi di tali parti solide tra sedgio e sfera che provocherebbero il bloccaggio della valvola.
- ridurre la quantità di sporco che può depositarsi nella cavità del corpo valvola.

**The SAT3 model** is an evolution of the SAT with the insertion of two rings (called Scraper Rings) inside and outside the seats.

The Scraper Rings have to:

- clean ball surface during valve operation
- protect the seats from abrasion by fluid solid content
- avoid wedging in of solids between seat and ball surface cause of valve blocking
- reduce dirt can fill body cavity

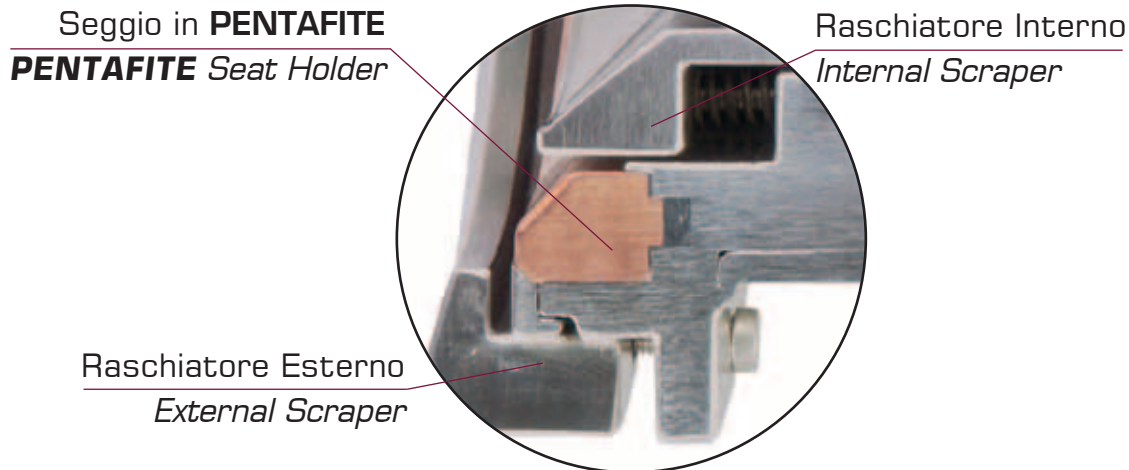

Come tutta la produzione PENTA le valvole della serie SAT3 sono progettate per essere equipaggiate con seggi metallici in PENTAFITE permettendo la realizzazione di valvole a sfera a tenuta metallica con **PERDITA ZERO** per servizi con temperature di esercizio continuo fino a 700°C.

Le particolari caratteristiche elasto-plastiche del materiale dei seggi PENTAFITE e la costruzione interamente bullonata permettono facili interventi di manutenzione, non necessitando di lavoro di adattamento tra sedi di ricambio e sfere.

Le valvole modello SAT3 sono disponibili in due versioni:

- Bi-direzionali, sia a sfera flottante o Trunnion mounted
- Monodirezionali, a sfera Trunnion mounted per montaggio con asse della tubazione verticale.

In questo caso le cavità del corpo sono lavorate in modo da favorire il drenaggio automatico ed evitare la sedimentazione del fluido all'interno della valvola.

Like all PENTA production, valves of SAT3 series are equipped with metallic seats in PENTAFITE that allow the manufacturing of metal seated ball valves with Bubble tight (no leakage) suitable for a wide range of services with working temperatures up to 700°C.

The typical elastic properties of PENTAFITE seats and the fully bolted construction, allow an easy maintenance without necessity of additional lapping of the spare seats against the ball,

The SAT3 model is available in two version:

- Bi-directional, both with floating ball or trunnion mounted
- Uni-directional, trunnion mounted ball for applications where pipe axis is vertical.

In this case body cavity is machined to obtain a complete body cavity draining avoiding fluid deposit inside the valve (best for bottom tank valves).

# VALVOLE A SFERA A SEGGI METALLICI METAL SEATED BALL VALVES



-100 °C +400 °C

## INTERVALLO DI PRODUZIONE - PRODUCTION RANGE

ANSI B 16.34	CLASSE - PRESSURE CLASS					
	150		300		600	
PN	16 - 25		40 - 50		64 - 100	
Diametri Nominali Nominal diameter	F	T	F	T	F	T
1/2"						
3/4"						
1"						
1 1/2"						
2"						
3"						
4"						
6"						

F = Sfera flottante - *Floating ball*

T = Sfera vincolata - *Trunnion mounted ball*

## ACCESSORI DISPONIBILI - AVAILABLE ACCESSORIES

Diversi accessori sono disponibili a richiesta  
*Many accessories are available on request*

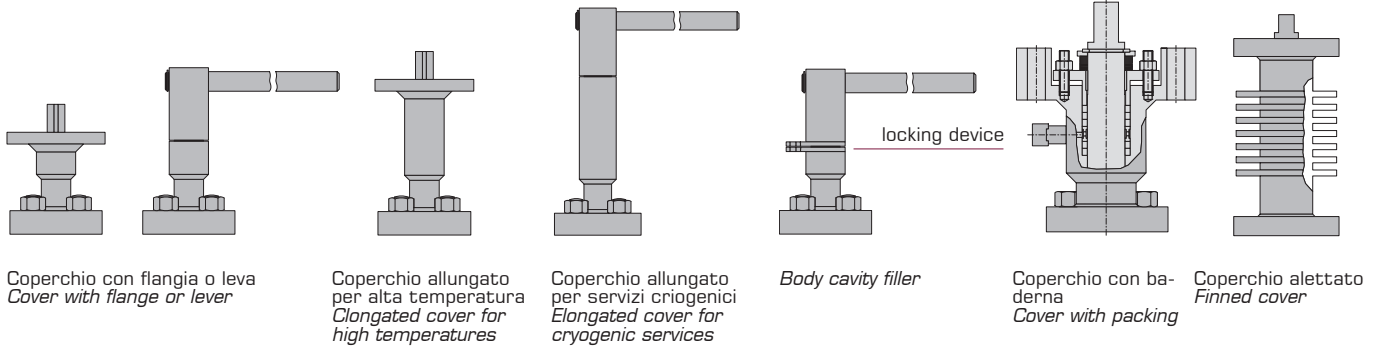

## OPERATORI DISPONIBILI - AVAILABLE OPERATORS

- Riduttori manuali
- Attuatori pneumatici a semplice o doppio effetto
- Attuatori elettrici
- Attuatori idraulici
- *Manual gears*
- *Single or double acting pneumatic actuators*
- *Electric actuator*
- *Hydraulic actuators*



<b>MATERIALI DISPONIBILI PER I SEGGI - AVAILABLE SEAT MATERIALS</b>					
Codice Code	Materiale Material	Durezza Hardness	Temperature di lavoro Working temperature	Pressioni di lavoro Working pressure	Servizio Service Limits
<b>S01</b>	<b>SILVER PENTAFITE</b> (Nickel + Graphite )	120 HB	-100°C / +780°C (148°F+1436°F)	ANSI 150 – 2500 PN10 - 420	For clean services both liquid or gas. For use with <b>HTC, HTCN, HCR, WC, CRC, ST6</b> ball coated
<b>R01</b>	<b>RED PENTAFITE</b> (Cu + Graphite )	100 HB	-100°C / +500°C (-148°F / +932°F)	ANSI 150 – 600 PN 10 - 100	For clean services both liquid or gas. Lower friction factors in dry gas or steam service. For use with <b>HTC, HTCN, HCR, ST6</b> ball coated
<b>B01</b>	<b>BLACK PENTAFITE</b> (Carbon + Graphite )	80 HB	Amb. / +400°C (Amb. / +752°F)	ANSI 150 – 300 PN 10 - 40	For low pressure specific services where <b>S01</b> and <b>R01</b> cannot be used due to corrosion problems. A ball coat is not strictly necessary and should be evaluated time to time
<b>WC</b>	<b>CARBURO DI TUNGSTENO</b> Tungsten Carbide Coat (Detonation Gun/HVOF)	1100 HV	Amb. / +350°C ( Amb. / +662°F )	ANSI 150 – 600 PN 10 - 100	For liquid or gas services with high presence of solids. Not suitable when small presence of caustic soda is expected. For use with WC ball coat
<b>CRC</b>	<b>CARBURO DI CROMO</b> Chrome Carbide (Detonation Gun)	800 HV	Amb. / +750°C ( Amb. / +1382°F )	ANSI 150 – 600 PN 10 - 100	For liquid or gas services with small presence of solids. Not suitable when small presence of caustic soda is expected.
<b>ST6</b>	<b>STELLITE Gr.6</b> (Detonation Gun/HVOF)	1000 HV	Amb. / +350°C ( Amb. / +662°F )	ANSI 150 – 600 PN 10 - 100	For liquid or gas services with small presence of solids. Suitable when small presence of caustic soda is expected. Best on dry gas or steam services. For use with <b>WC, CRC</b> ball coat
<b>PEEK</b>	<b>PoliEter EterKetone</b>		-100°C / +240°C ( -148°F / +464°F )	ANSI 150 – 1500 PN 10 - 100	For cryogenic services, down to -100°C only, with high pressures

<b>MATERIALI DISPONIBILI PER RIVESTIMENTO SFERE - AVAILABLE BALL COATING MATERIALS</b>					
Codice Code	Materiale Material	Durezza Hardness	Temperature di lavoro Working temperature	Pressioni di lavoro Working pressure	Servizio Service Limits
<b>WC</b>	<b>CARBURO DI TUNGSTENO</b> Tungsten Carbide (Detonation Gun/HVOF)	1100 HV	Amb. / +350°C ( Amb. / +662°F )	ANSI 150 – 2500 PN 10 - 420	For liquid or gas services with high presence of solids. Not suitable when small presence of caustic soda is expected.
<b>CRC</b>	<b>CARBURO DI CROMO</b> Chrome Carbide (Detonation Gun/HVOF)	800 HV	Amb. / +750°C ( Amb. / +1382°F )	ANSI 150 – 2500 PN 10 - 420	For liquid or gas services with small presence of solids. Not suitable when small presence of caustic soda is expected.
<b>ST6</b>	<b>STELLITE GR.6</b> (Detonation Gun/HVOF)	1000 HV	Amb. / +350°C ( Amb. / +662°F )	ANSI 150 – 2500 PN 10 - 420	For liquid or gas services with small presence of solids. Suitable when small presence of caustic soda is expected. Best on dry or steam services.

## GRADO DI TENUTA - TIGHTNESS

Tutte le valvole PENTA modello SAT 3 sono collaudate per verificarne la TENUTA PERFETTA (perdita zero alla prova idraulica dei seggi secondo ANSI B16.34 e a 6 bar con aria).

All PENTA valves SAT 3 model are tested to verify their BUBBLE TIGHTNESS (no visible leakage during hydraulic seat test according to ANSI B 16.34 and during low pressure air seats test at 100 psi)



penta s.r.l.

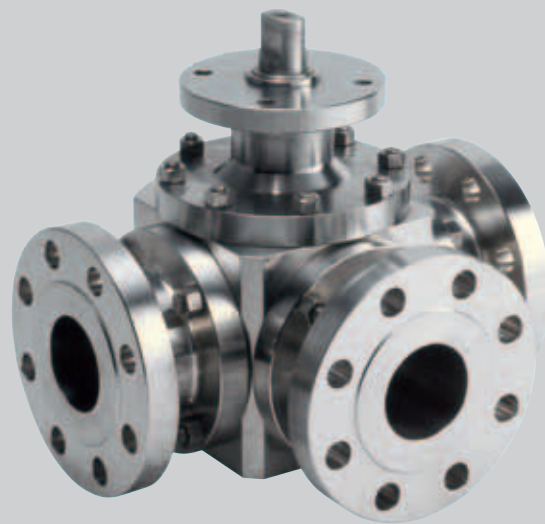

MODELLO / *MODEL*

# MULTIPOINT



Eurasian Conformity



Directive 2014/68/UE  
"PED"



II2G c IIC TX  
II2D c IIC TX

Directive 2014/34/UE  
"ATEX"

MULTIPOINT





Basandosi su una costruzione con sfera vincolata, (Trunnion mounted) PENTA realizza valvole a sfera a sedi metalliche a 3 vie, con passaggio a L oppure a T. Queste valvole usufruiscono di soluzioni tecniche uniche tipiche dei modelli SAT, che ancora oggi non trovano eguali nel mercato delle valvole.

Come tutta la produzione PENTA le valvole serie MULTIPORT sono progettate per essere equipaggiate con seggi metallici in PENTAFITE permettendo la realizzazione di valvole a seggi metallici con PERDITA ZERO per servizi con temperature di esercizio continuo da  $-100^{\circ}\text{C}$  a  $-400^{\circ}\text{C}$ .

Le caratteristiche elasto-plastiche della PENTAFITE e la costruzione interamente bullonata permettono facili interventi di manutenzione, non necessitando di lavoro di adattamento tra sedi di ricambio e sfere.

Tutte le valvole Multipoint sono equipaggiate con sfere Trunnion mounted e con seggi indipendenti su ogni via pre-caricati con molle.

*Basing on a trunnion mounted ball construction, PENTA can manufacture a range of 3-way metal seated ball valves, with "L" port or "T" port. The advanced solutions typical for SAT model are used on these valves that still has no equal on the market at present.*

*Like all PENTA production, MULTIPORT valves are equipped with metallic seats in PENTAFITE to allow the manufacturing of metal seated ball valves with absolutely ZERO LEAKAGE suitable for a wide range of services with working temperatures from  $-100^{\circ}\text{C}$  a  $-400^{\circ}\text{C}$ .*

*The typical elastic properties of PENTAFITE seats and the fully bolted construction allow an easy maintenance without necessity of additional lapping of the seats against the ball.*

*All valves Multipoint model are equipped with Trunnion mounted ball and with independent spring loaded seats on each way .*

Dimensionamenti <i>Design</i>	ANSI B16.34 / API 608 / EN12569 / EN17292 ASME VIII Div.1 / EN 12516-1
Estremità* <i>Valve ends</i>	Flangiate ANSI B16.5 / EN 1092-1 / DIN <i>Flanged</i> A saldare ANSI B16.25 <i>Butt weld</i>
Collaudo <i>Testing</i>	ANSI B16.104 / API 598 API 598 EN 12266-1 ISO 5208 BS 6755-1

\* Altre estremità disponibili a richiesta.  
*Other end connections are available on request.*

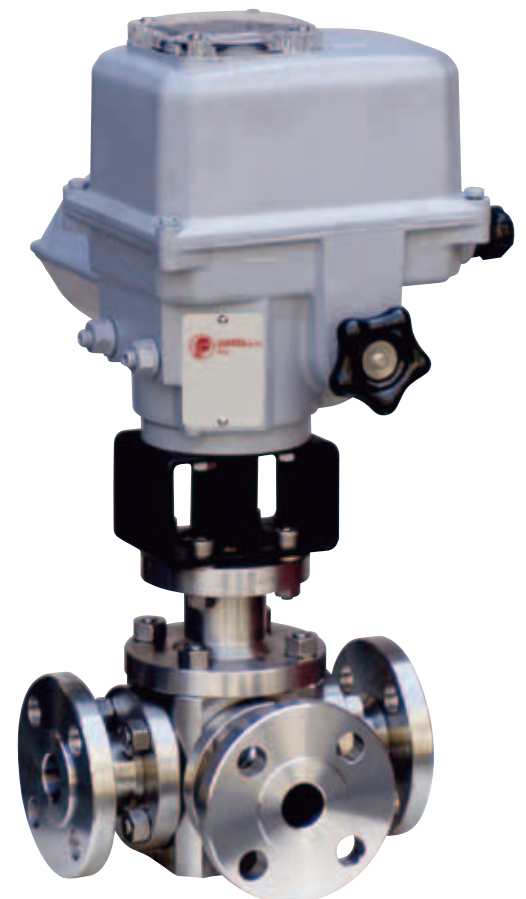

# VALVOLE A SFERA A SEGGI METALLICI

## METAL SEATED BALL VALVES



### Stelo

Gli steli sono 100% sovradimensionati rispetto alla coppia attesa al max. DP di rating.

### Stem

Stem are 100% oversized against expected torque at max. rated DP.

### Guarnizioni

Sono utilizzate esclusivamente guarnizioni in Grafoil® resistenti alle alte temperature; nessun materiale polimerico è impiegato.

### Gasket

Only Grafoil® gasket are used, inherently resistant to high temperatures; no polymers are used.

### Tenuta stelo

Tenuta stelo di progetto unico (brevettato). La molla posta all'estremità superiore dello stelo fornisce il precarico per la tenuta alle basse pressioni, recupera usura e giochi dovuti a dilatazioni differenziali tra stelo e coperchio.

### Stem tightness

Unique stem seal design (patented). The spring placed at stem top gives the contact load for low pressure tightness and the adjustment for wearing and clearance for different dilatation between stem and cover.

### Coperchio superiore

Tutte le valvole 3 VIE sono dotate di un coperchio superiore bullonato per una rapida sostituzione del gruppo stelo/guarnizioni.

### Upper cover

All 3 WAY valves are provided with bolted upper cover for quick and easy stem assembly maintenance.

### Sfera

Sfere rettificate ad alta precisione sono prodotte internamente e quindi indurite superficialmente con riporti a tecnologia avanzata. Tutte le sfere sono "trunnion mounted" per evitare carichi laterali alle sedi di tenuta.

### Ball

Very high precision grounded balls are produced inside and then hard coated with most advanced system. All balls are "trunnion mounted" in order to avoid lateral load against the seats.

### Flange - Bulloneria

Tutti gli accoppiamenti flangiati sono dimensionati secondo ASME VIII Div. 1.

### Bolting and Flanges

All flanges connections are designed according to ASME VIII Div. 1

### Seggi

Ogni via è predisposta con sede di tenuta indipendente. Le sedi metalliche sono precaricate con molle in entrambi i lati della valvola, anche nella versione flottante, per una completa bi-direzionalità.

### Seats

Every way is predisposed with independent seat. Metallic seats are loaded with springs on both valve side, also for floating ball construction, for a full bi-directionality.

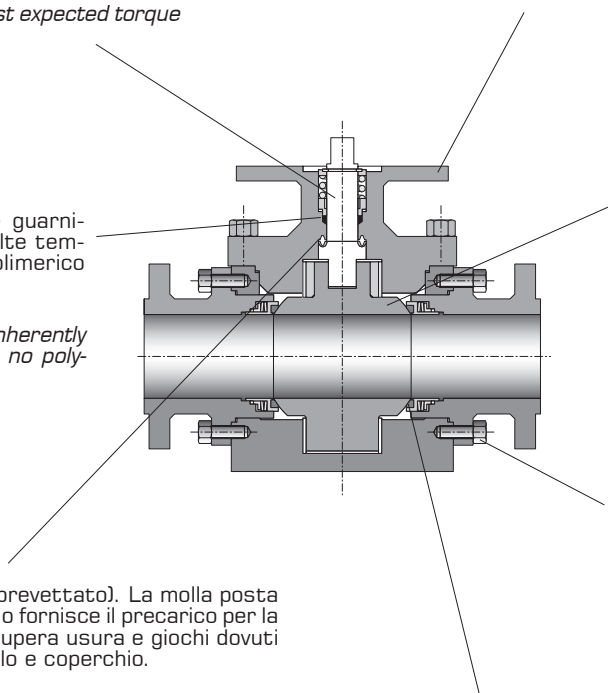



## MATERIALI DISPONIBILI PER I SEGGI - AVAILABLE SEAT MATERIAL

Codice Code	Materiale Material	Durezza Hardness	Temperature di lavoro Working temperature	Pressioni di lavoro Working pressure	Servizio Service Limits
<b>S01</b>	<b>SILVER PENTAFITE</b> (Nickel + Graphite)	120 HB	-100°C / +780°C (-148°F / +1436°F)	ANSI 150 – 2500 PN 10 - 420	For clean services both liquid or gas. For use with <b>HTC, HTC/N, HCR, WC, CRC, ST6</b> ball coated
<b>R01</b>	<b>RED PENTAFITE</b> (Cu + Graphite)	100 HB	-100°C / +500°C (-148°F / +932°F)	ANSI 150 – 600 PN 10 - 100	For clean services both liquid or gas. Lower friction factors in dry gas or steam service. For use with <b>HTC, HTC/N, HCR, ST6</b> ball coated
<b>B01</b>	<b>BLACK PENTAFITE</b> (Carbon + Graphite)	80 HB	Amb. / +400°C (Amb. / +752°F)	ANSI 150 – 300 PN 10 - 40	For low pressure specific services where <b>S01</b> and <b>R01</b> cannot be used due to corrosion problems. A ball coat is not strictly necessary and should be evaluated time to time
<b>WC</b>	<b>CARBURIO DI TUNGSTENO</b> Tungsten Carbide Coat (Detonation Gun/HVOF)	1100 HV	Amb. / +350°C ( Amb. / +662°F )	ANSI 150 – 300 PN 10 - 40	For liquid or gas services with high presence of solids. Not suitable when small presence of caustic soda is expected. For use with WC ball coat
<b>ST6</b>	<b>STELLITE Gr.6</b> (Detonation Gun/HVOF)	1000 HV	Amb. / +350°C ( Amb. / +662°F )	ANSI 150 – 300 PN 10 - 40	For liquid or gas services with small presence of solids. Suitable when small presence of caustic soda is expected. Best on dry gas or steam services. For use with <b>WC, CRC</b> ball coat
<b>PK1</b>	<b>PEEK</b> (Polietileneeterketone)		-100°C. / +240°C (-148°F / +464°F)	ANSI 150 – 600 PN 10 - 100	For liquid or gas services with high frequency of valve operation.

## MATERIALI DISPONIBILI PER RIVESTIMENTO SFERE - AVAILABLE BALL COATING MATERIALS

Codice Code	Materiale Material	Durezza Hardness	Temperature di lavoro Working temperature	Pressioni di lavoro Working pressure	Servizio Service Limits
<b>HTC</b>	<b>NITRURI DI TITANIO</b> Titanium Nitride (PVD)	2500 HV	-100°C / +600°C ( -148°F / +1112°F )	ANSI 150 – 600 PN 10 - 100	For clean services both liquid or gas. For gas and steam up to 180°C
<b>HTCN</b>	<b>CARBO-NITRURI DI TITANIO</b> Carbo-Titanium Nitride (PVD)	3500 HV	-100°C / +400°C ( -148°F / +752°F )	ANSI 150 – 600 PN 10 - 100	For liquid or gas services with small presence of solids. For gas and steam up to 180°C
<b>HCR</b>	<b>NITRURI DI CROMO</b> Chrome- Nitride (PVD)	3000 HV	Amb. / +750°C ( Amb. / +1382°F )	ANSI 150 – 300 PN 10 - 40	For clean services both liquid or gas. Best on oxidizing services
<b>WC</b>	<b>CARBURIO DI TUNGSTENO</b> Tungsten Carbide (Detonation Gun/HVOF)	1100 HV	Amb. / +350°C ( Amb. / +662°F )	ANSI 150 – 300 PN 10 - 40	For liquid or gas services with high presence of solids. Not suitable when small presence of caustic soda is expected.
<b>CRC</b>	<b>CARBURIO DI CROMO</b> Chrome Carbide (Detonation Gun/HVOF)	800 HV	Amb. / +750°C ( Amb. / +1382°F )	ANSI 150 – 300 PN 10 - 40	For liquid or gas services with small presence of solids. Not suitable when small presence of caustic soda is expected.
<b>ST6</b>	<b>STELLITE GR.6</b> (Detonation Gun/HVOF)	1000 HV	Amb. / +350°C ( Amb. / +662°F )	ANSI 150 – 300 PN 10 - 40	For liquid or gas services with small presence of solids. Suitable when small presence of caustic soda is expected. Best on dry or steam services.

## GRADO DI TENUTA - TIGHTNESS

Tutte le valvole PENTA modello MULTIPOINT sono collaudate per verificarne la TENUTA PERFETTA (perdita zero alla prova idraulica dei seggi secondo ANSI B16.34 e a 6 bar con aria).

All PENTA valves MULTIPOINT model are tested to verify their BUBBLE TIGHTNESS (no visible leakage during hydraulic seat test according to ANSI B 16.34 and during low pressure air seats test at 100 psi)

# VALVOLE A SFERA A SEGGI METALLICI METAL SEATED BALL VALVES



## INTERVALLO DI PRODUZIONE - PRODUCTION RANGE

CLASSE - PRESSURE CLASS			
ANSI B 16.34	150	300	600
PN	16 - 25	40 - 50	64 - 100
Diametri Nominali Nominal diameter	T	T	T
1/2"			
3/4"			
1"			
1 1/2"			
2"			
3"			
4"			
6"			
8"			
10"			

T = Sfera vincolata - Trunnion mounted ball T = Sfera vincolata - Trunnion mounted ball

## ACCESSORI DISPONIBILI - AVAILABLE ACCESSORIES

Diversi accessori sono disponibili a richiesta  
Many accessories are available on request

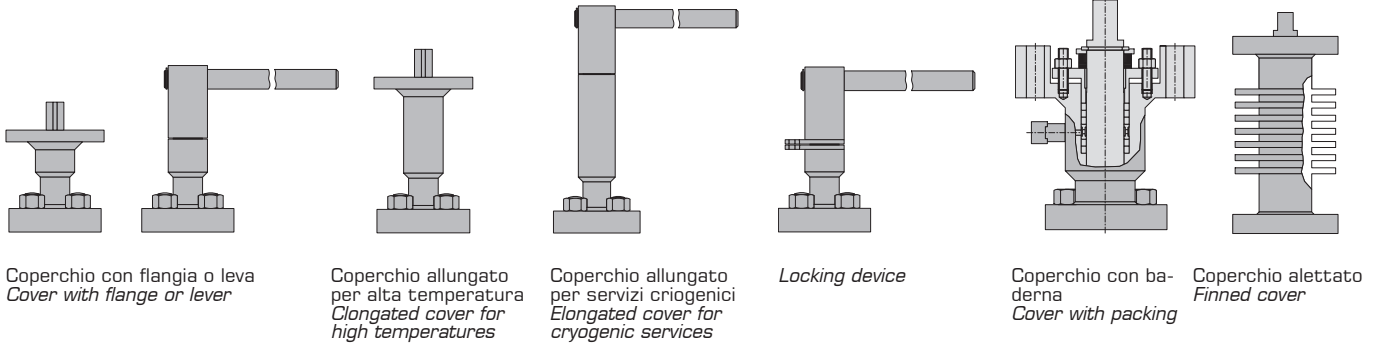

Coperchio con flangia o leva  
Cover with flange or lever

Coperchio allungato  
per alta temperatura  
Elongated cover for  
high temperatures

Coperchio allungato  
per servizi criogenici  
Elongated cover for  
cryogenic services

Locking device

Coperchio con ba-  
derna  
Cover with packing

Coperchio alettato  
Finned cover

## OPERATORI DISPONIBILI - AVAILABLE OPERATORS

- Riduttori manuali
- Attuatori pneumatici a semplice o doppio effetto
- Attuatori elettrici
- Attuatori idraulici
- Manual gears
- Single or double acting pneumatic actuators
- Electric actuator
- Hydraulic actuators



# MULTIPOINT

-100 °C +400 °C

## Tipica Valvola 3-VIE 90°/120° Trunnion Typical 3WAY 90°/120° Trunnion

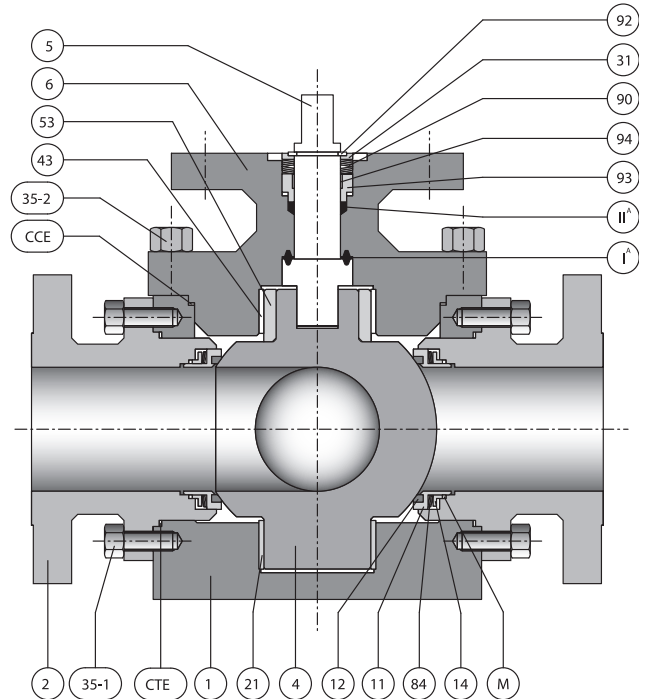

### Componenti - Valve parts

CCE	Guarniz. Coperchio Sup.	Upper cover gasket
CTE	Guarniz. Corpo/Terminale	Body-Connector gasket
M	Guarnizione Seggio	Seat gasket
II <sup>A</sup>	Guarnizione Secondaria	Secondary stem seal
I <sup>A</sup>	Guarnizione Primaria	Primary stem seal
94	Bussola Stelo	Stem plain bearing
93	Premi Baderna	Gland
92	Fermo Anello Stelo	Stem retaining ring
90	Molle Stelo	Stem spring
84	Molle Seggio	Seat spring
53	Manicotto	Coupling
43	Bussola Manicotto	Coupling plain bearing
35-2	Tiranti Coperchio superiore	Upper cover Bolts
35-1	Tiranti Corpo/Terminale	Body/Connector Bolts
31	Anello premi molla Stelo	Stem spring compression ring
21	Bussola Trunnion	Trunnion plain bearing
14	Premigrafoil	Compression ring
13	Cassetto Corpo	Seat holder
12	Seggio	Seat
6	Coperchio superiore	Upper cover
5	Stelo	Stem
4	Sfera	Ball
2	Terminale	Body Connector
1	Corpo	Body

**P. No. Parte - Part Name**

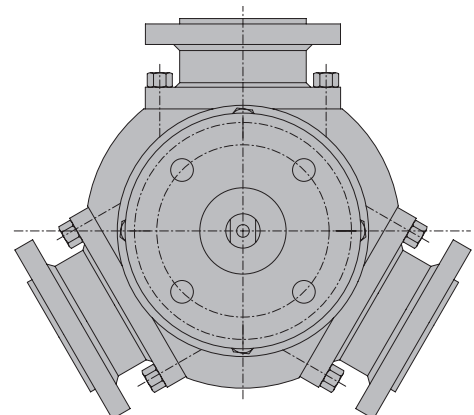
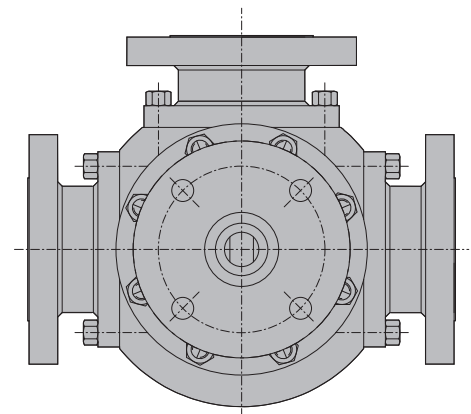

Le valvole possono essere realizzate in qualsiasi materiale in accordo ai requisiti del Committente purchè in barre, barre o anelli fucinati e forgiati  
Valves can be manufactured in all materials according Customer requirements when available in form of bars, forged bars or rings

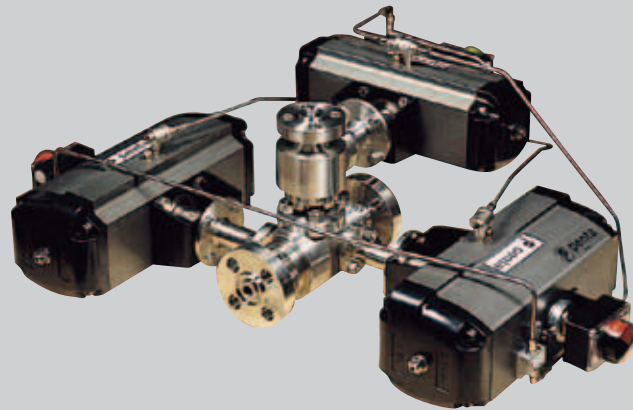

**PROGETTI SPECIALI / SPECIAL DESIGNS**



Directive 2014/68/UE  
"PED"



II2G c IIC TX  
II2D c IIC TX

Directive 2014/34/UE  
"ATEX"



## Progetti speciali

Sulla base della tecnologia sviluppata negli anni, PENTA è in grado di progettare valvole a sfera speciali a seggi metallici per un intervallo di condizioni di esercizio estremamente ampio: da -200°C fino a 780°C.

Come tutta la produzione Penta, anche le valvole speciali sono progettate per essere equipaggiate con seggi metallici in PENTAFITE, permettendo così di ottenere valvole a seggi metallici con **PERDITA ZERO** nelle condizioni più estreme.

Le caratteristiche elasto-plastiche del materiale PENTAFITE, permettono facili interventi di manutenzione, senza necessità di lavoro di adattamento tra sedi di ricambio e sfere.

*Basing on property technologies developed in years of activity in the fluid handling, PENTA is able to design special ball valves for a wide range of working conditions: from -200°C up to 780°C.*

*Like all PENTA production range, also SPECIAL valves are equipped with metallic seats in PENTAFITE allowing to obtain bubble tight metal seated ball valves with absolutely ZERO LEAKAGE with no additional lapping of seats against ball.*

*The typical elastic properties of PENTAFITE seats allow an easy maintenance without necessity of additional lapping of the seats against the ball.*

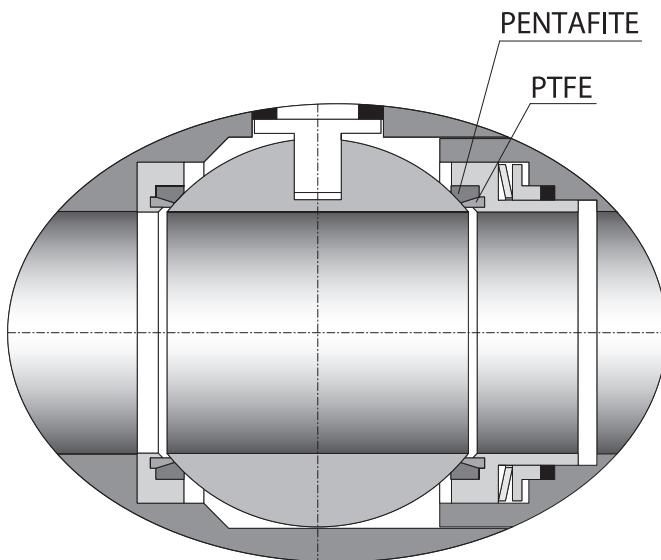

Seggio con labbro interno di pulizia

*Seat arrangement with internal scraping ring*

Valvola con anelli raschiatori ad una sede con sfera trunnion

*One seat with scrapers and trunnion mounted ball*

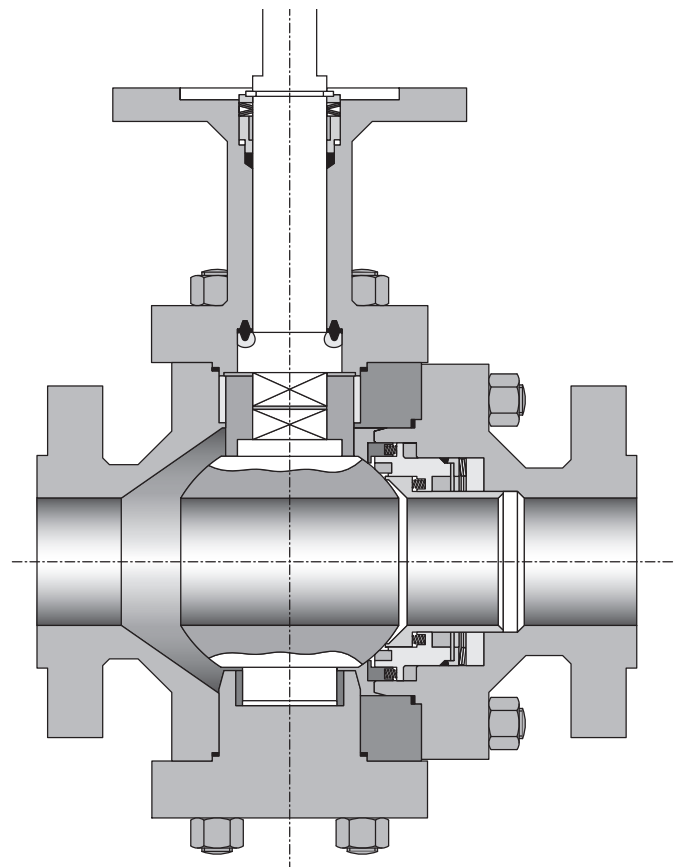

Sistema valvola a doppia sfera con drenaggio intermedio

*Double block and bleed system (two balls)*

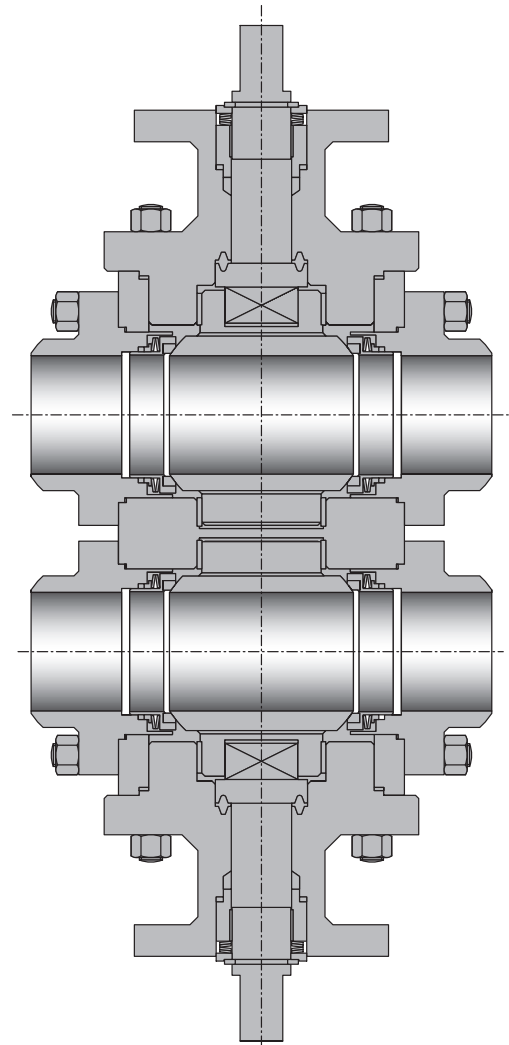
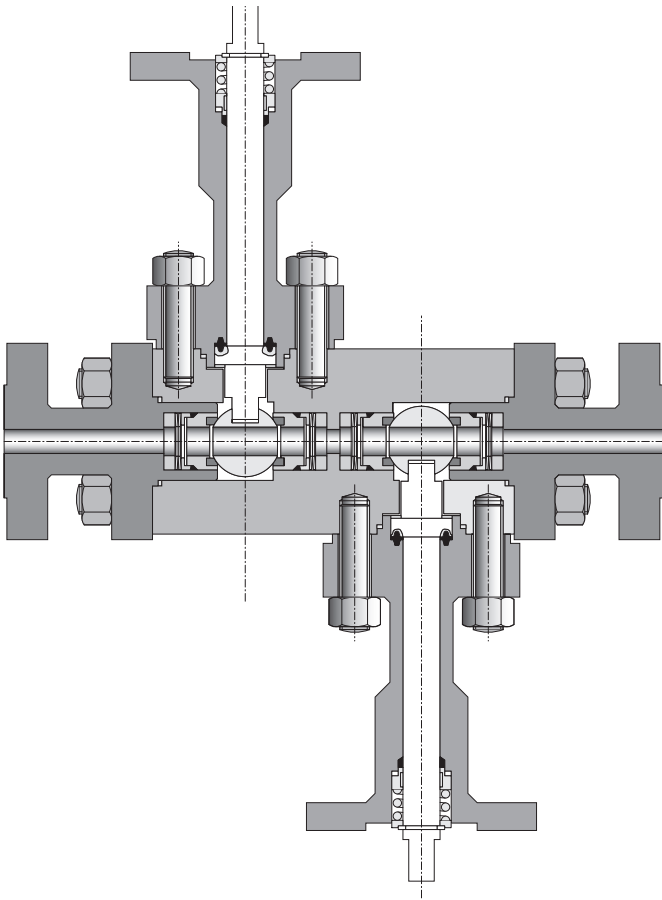

Valvole a due sfere accoppiate con o senza unico operatore

*Double block construction with or without unique operator*



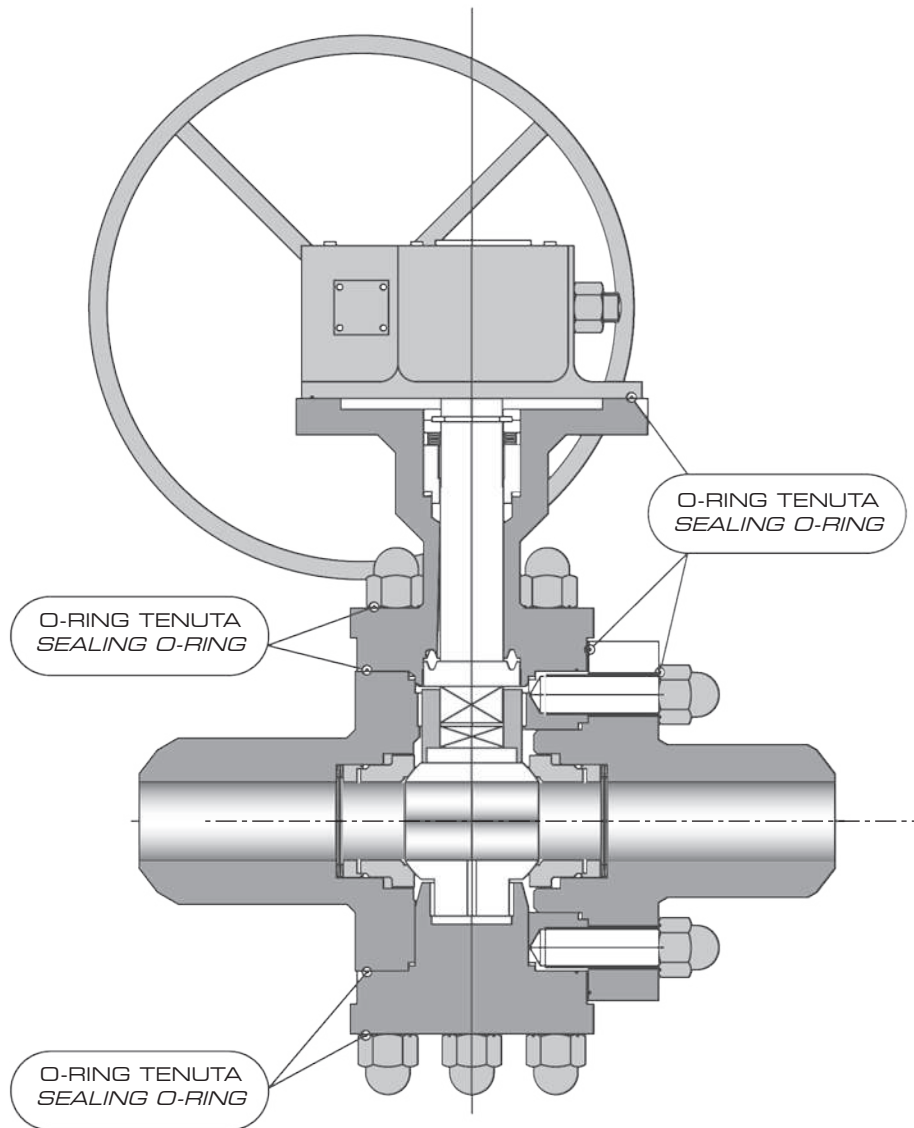

Valvole sottomarine (non di profondità)  
*Subsea valves (not for deep see applications)*





Pos.	Servizio Service Conditions	Temp. (°C)	Press. (bar)	Tipo valvola Valve size and Model	Classe Class	Cliente Client
1	<b>ACETILENE</b> ACETYLENE			da 1/2" a 2" from 1/2" to 2"	300	ERIKS (NL)
2	<b>ACIDO ISOFTALICO</b> con 30% parti solide in H2O e H2 ISOFTALIC ACID with 30% solid parts in H2o and H2	275	60	DN 3" - SAT3	900	SISAS S.p.A. Milano
3	<b>ACIDO SOLFIDRICO</b> SULPHYDRIC ACID			1 1/2" - 4"	150	AGIP PETROLI Sannazzaro de' Burgundi (PV)
4	<b>ACIDO SOLFORICO, ACETICO, FURFURILICO, FORMICO + SILICE</b> (1 manovra ogni min.) SULPHURIC ACID, ACETIC, FURFURILIC, FORMIC VAPOUR + SILICA (1 operation per min.)	300	15	2" 8" SAT3	300 300	CAPURRO SpA Lecce
5	<b>ACQUA</b> WATER	AMB.	25	1"	300	E.N.E.L. - Centrale S.GILLA
6	<b>ACQUA</b> WATER		500	1" / 1 1/2"	4500	MIDIS S.Donato Milanese (MI)
7	<b>ACQUA</b> WATER	0 / 110	2,2 - 5	DN 1" - AP20P	150	ASEKO OY Masala FINLAND
8	<b>ACQUA</b> WATER	50	60	DN 1/2" e 2" - AP606-	PN 100	ASEKO OY Masala FINLAND
9	<b>ACQUA</b> WATER	-38/+275	80	DN 3/4" e 1" - AP606-	600	GROVE DRESSER ITALIA Voghera (PV)
10	<b>ACQUA DI MARE</b> SEA WATER	120		3" sandwich	150	E.N.E.L. Porto Scuso (CA)
11	<b>ACQUA DEMINERALIZZATA</b> WATER (DEMINERALIZED)	350	110	2" / 2 1/2"	1500	C.C.R. EURATOM Ispra (VA)
12	<b>ACQUA DEMINERALIZZATA</b> WATER (DEMINERALIZED)	350	200	46 mm	2500	C.C.R. EURATOM Ispra (VA)
13	<b>ACQUA DEMINERALIZZATA</b> + IDRAZINA PH 9 WATER (DEMIN.) + HYDRAZINE PH 9	311		10"	1500	C.I.S.E - CENTRO INFORMAZIONI STUDI ESPERIENZE Segrate (MI)
14	<b>ACQUA + FOSFATI</b> WATER + PHOSPHATES		110	1/2"	800	E.N.E.L. Porto Marghera (VE)
	<b>ACQUA + GLICOLE</b> WATER + GLYCOL	85 - 150	5 - 8	DN 3" - AP64	150	ASEKO OY Masala FINLAND
	<b>ACQUA + GLICOLE</b> WATER + GLYCOL	AMB	6	2"	150	S.T.C. Bergamo
	<b>ACQUA + GLICOLE</b> WATER + GLYCOL	90	80	ODYM 1/2"	800	ABL AUTOMAZIONE
	<b>ACQUA + IDRAZINA</b> WATER + HYDRAZINE	180		da 1/2" a 10" from 1/2" to 10"	300	AZIENDA SERVIZI MUNICIPALIZZATI Brescia
	<b>ACQUA + OLIO</b> WATER + OIL			2"	300	ASEKO OY HELSINKY (SF)
	<b>ACQUA / VAPORE</b> WATER / STEAM	310	100	da 1/2" a 4" from 1/2" to 4"	1500	S.I.E.T. Piacenza
15	<b>ACQUA + VAPORE + UO2</b> WATER + STEAM + UO2			4" (tempo di manovra / operation in 0,7 sec.)	1500 SPECIAL	C.C.R. EURATOM Ispra (VA)
16	<b>ACQUA SURRISCALDATA</b> WATER (SUPERHEATED)	160	10	da 1" a 4" - 3 vie from 1" to 4" - 3 way	1500	BREDA NARDI COSTRUZIONI AERONAUTICHE
17	<b>ACQUA SURRISCALDATA</b> WATER (SUPERHEATED)	185	255	3"	1500	E.N.E.L. Ostiglia (MN)
	<b>ACQUA SURRISCALDATA</b> WATER (SUPERHEATED)	271	90	DN 3" - SAT	900	ALFA VALVOLE S.r.l. Casorezzo (MI)
	<b>ACQUA SURRISCALDATA</b> WATER (SUPERHEATED)		180/200	DN 1/2" - SAT	1500	ENEL Ostiglia Ostiglia (MN)
18	<b>ACRILONITRILE</b> ACRYLONITRILE			da 2" a 4" - seggi integrali from 2" to 4" - cavity filler	300	ENICHEM ANIC Ravenna



Pos.	Servizio Service Conditions	Temp. (°C)	Press. (bar)	Tipo valvola Valve size and Model	Classe Class	Cliente Client
19	<b>ADESIVO</b> ADHESIVE	350	40	DN2" AP11NB	PN40	NAR SPA Legnaro (PD)
20	<b>ALCHILAZIONE GPL ACIDO HF - NH3</b> GPL (ALKYLATION) ACID HF - NH3			da 1/2" a 4" from 1/2" to 4"	300	AGIP PETROLI Sannazzaro de' Burgundi (PV)
21	<b>ALDEIDI + H2</b> ALDEHYDE + H2	400	70	DN 1/2" - SAT	900	CONDEA AUGUSTA Augusta (SR)
22	<b>AMMINA RICCA</b> RICH AMINE	115	97	DN14" SAT	900	MOTOR OIL HELLAS GREECE
23	<b>AMMONIACA</b> AMMONIA	-33		da 1/2" a 20" from 1/2" to 20"	300	ENICHEM ANIC Manfredonia (FG)
24	<b>ANIDRIDE FTALICA</b> AIR	240		DN 3" - W3 SATJ-AE	PN 16	LONZA SPA S. Giovanni Valdarno (AR)
25	<b>AMMONIACA LIQUIDA</b> LIQUID AMMONIA	-18 / 65	20	DN3" - DN6" SAT	300	PETRO CHINA DAQING OIL FIELD Methyl Alcohol Plant Ammonia Tech. Revamping PEOPLE'S REP OF CHINA
26	<b>ANIDRIDE MALEICA</b> ANHYDRIDE		10	DN 2" - AP 103-	150	EXXON CHEMICAL MEDITERRANEA Vado Ligure (SV)
27	<b>ARGON LIQUIDO</b> LIQUID ARGON	-200	20	da 1" a 3" SAT CRIO from 1" to 3"	300	P.G.C. Salerno
28	<b>ARIA</b> AIR	50	8,5	DN 2" - AP64	150	ASEKO OY Masala FINLAND
29	<b>ARIA</b> AIR	400	15	da 1" a 4" from 1" to 4"	300	FIAT ENGINEERING
30	<b>ARIA CALDA</b> AIR (HOT)	300	12	1" - 2"	300	TERRUZZI Milano
31	<b>ARIA CALDA</b> AIR (HOT)	460	28	DN 2" - 4" - SAT-	600	ABB KENT TAYLOR S.p.A.
32	<b>ARIA N2, HC, HS, VAPORE</b> AIR N2, HC, HS, STEAM	300	12	4" - 3 vie 4" - 3 way	300	BP AMBURGO
33	<b>ASFALTO LIQUIDO</b> ASPHALT (LIQUID)	400	6	da 1" a 4" from 1" to 4"	300	SHELL AMSTERDAM
34	<b>AZOTO / IDROGENO</b> NITROGEN / HYDROGEN	320	6	da 1" a 3/4" from 1" to 3/4"	300	HUMIDRYER ITALIANA Novara
35	<b>AZOTO + ARIA</b> NITROGEN + AIR	50	8,5	DN 2" - AP64	150	ASEKO OY Masala FINLAND
36	<b>AZOTO</b> NITROGEN	35/150	38	DN 6" - SAT	300	INTERVALVE PTY LTD. RivoniaSandton RSA
37	<b>AZOTO</b> NITROGEN	400	23	DN 1" - AP 60 -	300	PALL ITALIA SRL Milano
38	<b>AZOTO LIQUIDO</b> LIQUID NITROGEN	-200	1,5	da 1" a 3" SAT CRIO from 1" to 3"	300	S. O. L. Piombino (LI)
39	<b>AZOTO + OSSIGENO + ARGON</b> NITROGEN + OXIGEN + ARGON	-196	10	DN3" / DN4" - SAT crio -	PN40	CHEMGAS Brindisi
40	<b>BENZENE E CUMENE</b> BENZENE AND CUMENE	300	2	DN1.1/2"	150	ARKEMA SRL Spinetta Marengo (AL)
41	<b>BENZINA - FUEL GAS</b> GASOLINE - FUEL GAS	Amb.	6	DN 1" - AP606	600	AGIP PETROLI P.to Marghera (VE)
42	<b>BENZINA - FUEL OIL</b> GASOLINE - FUEL OIL	130		da 1 1/2" a 6" from 1 1/2" to 6"	300	AMOCO ITALIA Cremona
43	<b>BENZINA - FUEL OIL</b> GASOLINE - FUEL OIL	140	14	DN 1" - AP606	600	AGIP PETROLI P.to Marghera (VE)
44	<b>BENZINA</b> GASOLINE	200	11,7	SAT - 6"	300	AGIP PETROLI P.to Marghera (VE)
45	<b>BENZINA</b> GASOLINE	200	11,7	DN 10" - SAT APT3	300	AGIP PETROLI P.to Marghera (VE)
46	<b>BENZINA</b> GASOLINE	180	14	DN 8" - SAT	300	AGIP PETROLI P.to Marghera (VE)



Pos.	Servizio Service Conditions	Temp. (°C)	Press. (bar)	Tipo valvola Valve size and Model	Classe Class	Cliente Client
47	<b>BITUME</b> BITUMEN	240	5,4	DN 3/4" - SAT	600	AGIP PETROLI Sannazzaro de' Burgundi (PV)
48	<b>CAFFE'</b> COFFEE EXTRACT	180	25	1"	300	THERMOMESS Milano
49	<b>CARBONE + CALCARE + AZOTO</b> COAL/FLUX LIMESTONE + NITROGEN	500	11	6" SAT3	300	ENEL C.R.T.N. Pisa
50	<b>CARBONE + CALCARE</b> COAL LIMESTONE	400		4" SAT3	150	ENIRICERCHE Pisa
51	<b>CATALIZZATORE</b> CATALYST	300	63	2" rb a 1/2" 2" rb to 1/2"	600	DOW CHEMICAL
52	<b>CATALIZZATORE</b> CATALYST	400/700	atm.	DN 4"-6" - SAT3	300	AGIP PETROLI Priolo (SR)
53	<b>CATALIZZATORE</b> CATALYST	400/700	atm.	DN 1 1/2" - 4" - SAT3	300	AGIP PETROLI Priolo (SR)
54	<b>CATALIZZATORE</b> CATALYST	20/700	1 - 5	DN 1" - SAT	150	ASEKO OY Masala FINLAND
55	<b>CATALIZZATORE FRESCO</b> FRESH CATALYST	480	2	DN 3/4" - SAT	300	AGIP PETROLI Sannazzaro de' Burgundi (PV)
56	<b>CATALIZZATORE + ARIA</b> CATALYST + AIR	700	5	2"	600	AGIP PETROLI Sannazzaro de' Burgundi (PV)
57	<b>CATALIZZATORE + ARIA</b> CATALYST + AIR	Amb.	4	DN 6" - AP64	150	LG BALL VALVES LTD. Walsall, West Midlands GB
58	<b>CATALIZZATORE FRESCO + AZOTO</b> (1 manovra ogni 20 sec.) CATALYST FRESH + NITROGEN (1 operation every 20 sec.)	343	4	2" SAT3	300	AGIP PETROLI Sannazzaro de' Burgundi (PV)
59	<b>CATALIZZATORE FRESCO + IDROGENO</b> CATALYST FRESH + HYDROGEN	343	4	2"	300	AGIP PETROLI Sannazzaro de' Burgundi (PV)
60	<b>CATALIZZATORI IN GAS DI</b> <b>COMBUSTIONE</b> CATALYST IN FUEL GAS	714		2"	300	AMOCO
61	<b>CATALIZZATORE SOLIDO</b> SOLID CATALYST	450	6	DN 4" 6" e 10" - APT3-	150 300	LONZA SPA Ravenna
62	<b>CATRAME</b> TAR	300	10	DN 3" e 4" - AP68-	PN 16	J.S. COCK A/S Oslo - NORWAY
63	<b>CENERE</b> ASH	250	12	2"	150	ENIRICERCHE
64	<b>CLOROPRENE</b> CHLOROPRENE	120		da 2" a 4" - seggi integrali from 2" to 4" - integral seats	300	ENICHEM ANIC Ravenna
65	<b>CLORURO DI VINILE</b> VINYL CHLORIDE	120		da 2" a 4" - seggi integrali from 2" to 4" - integral seats	300	ENICHEM ANIC Ravenna
66	<b>CO</b> CO	300	10	1"	300	TERNI INDUSTRIE CHIMICHE
67	<b>CO2</b> CO2		160	DN 3/4" 1.1/2" - AP10HP	PN160	VENTIL BV
68	<b>COLLE</b> GLUE	300		DN 3" - AP68 DN 2" - AP10N	PN16 PN16	FILLATTICE SPA Monza (MI)
69	<b>CWS</b> CWS	160	24	1 1/2"	300	E.N.E.L. - Centrale S.GILLA
70	<b>DESOLVENTIZZAZIONE FDS</b> DESOLVENTIZATION FDS			10"	150	SAMOR Casalpuusterlengo
71	<b>DIAMANTI</b> DIAMOND STONES	Amb.	Grav.	DN 4" - 3WY -	PN 16	METMAR South Africa
72	<b>ESANO</b> HEXANE	AMB.		da 3/4" a 2" from 3/4" to 2"	300	HUMIDRYER ITALIANA Novara
73	<b>ETANO</b> ETHANE	-91	21,5	DN6" SAT crio	300	CHINA PETROLEUM - LANZHOU ETHYLENE PROJECT PEOPLE'S REP. OF CHINA



Pos.	Servizio Service Conditions	Temp. (°C)	Press. (bar)	Tipo valvola Valve size and Model	Classe Class	Cliente Client
74	<b>ETILENE</b> <i>ETHYLENE</i>	-101/+66	22	DN4" SAT crio	300	CHINA PETROLEUM - LANZHOU ETHYLENE PROJECT PEOPLE'S REP OF CHINA
75	<b>ETILENE LIQUIDO</b> <i>LIQUID ETHYLENE</i>	-104	12	DN3" and Dn4" - SAT crio	300	INNOVENE SOLVAY Rosignano Solvay (LI)
76	<b>FANGHIGLIA</b> <i>SLURRY</i>	320	160	DN 1/2" e 1" - SAT3 -	PN 250	PLASTINOX AG Allschwil - Switzerland
77	<b>FLUORO + HF</b> <i>FLUORINE + HF</i>	250	4	DN 2" - AP10NB	150	HUMIDRYER ITALIANA Novara
78	<b>FLUORURATI</b> <i>FLUORINE</i>	300	1	DN 1" - 3WL-	300	AUSIMONT S.p.a. Spinetta Marengo (AL)
79	<b>FREON</b> <i>FREON</i>	-15 / +50	7 / 20	1" - 1 1/2"	300	MOSSREF - MOSSEL BAY OFFSHORE PROJ. SOUTH AFRICA
80	<b>FUMI</b> <i>EXHAUST GAS</i>	150/350		DN 1"-2" - AP10N -	150	SDI AUTOM. IND.LE Milano
81	<b>FUMI</b> <i>EXHAUST GAS</i>	350		DN 2" - AP64 -	150	ENEL S.p.A. Brindisi
82	<b>GAS</b> <i>GAS</i>	850	12	1 1/2" - 2"	2500	ENIRICERCHE
83	<b>GAS</b> <i>GAS</i>	450	100	7,7 mm / 10 mm / 14 mm / 20 mm / 25 mm	1500	SHELL RESEARCH LABORATORIUM AMSTERDAM
84	<b>GAS</b> <i>GAS</i>	-196		3/4"	900	SHELL U.K.
85	<b>GAS</b> <i>GAS</i>	-85/+349		da 1/2" a 3" from 1/2" to 3"	900	STONE & WEBSTER
86	<b>GAS</b> <i>GAS</i>	50	5 - 6	DN 1/2" - AP20P	150	ASEKO OY Masala FINLAND
87	<b>GAS</b> <i>GAS</i>	320	75	DN 1.1/2" - SAT	600	INTERNATIONAL BALL VALVES LTD Suffolk ENGLAND
88	<b>GAS</b> <i>GAS</i>	50	130	DN 4" - SAT-	1500	ALFA VALVOLE Srl Casorezzo (MI)
89	<b>GAS</b> <i>GAS</i>	400	1	DN 1/2" e 1.1/4" - AP 64-	150	CISE SPA Milano
90	<b>GAS</b> <i>GAS</i>	550	30	DN 3" - AP 64-	150	ELETTROFLUID SRL Milano
91	<b>GAS</b> <i>GAS</i>	316	31	DN 1 1/2" - AP 606-	600	KITZ CORPORATION Barcelona -Spain
92	<b>GAS COMBUSTIBILE</b> <i>FUEL GAS</i>	46	10	DN3"	150	KHARTOUM REFINERY COMANY SUDAN
93	<b>GAS SOUR</b> <i>SOUR GAS</i>	100		DN1.1/2" and DN2" AP10NU	150	CHEVRON TEXACO Singapore
94	<b>GAS INERTE</b> <i>INERT GAS</i>	100		DN 1.1/2" - AP64 -	150	TORMENE Due Carrare (PD)
95	<b>GAS + H2S</b> <i>GAS + H2S</i>	60	7	3/4"	800	AGIP PETROLI Sannazzaro de' Burgundi (PV)
96	<b>GAS + H2S</b> <i>GAS + H2S</i>	65	3,4	DN 1.1/2" - AP606 -	600	AGIP PETROLI P.to Marghera (VE)
97	<b>GAS + H2S + H2O</b> <i>GAS + H2S + H2O</i>	-47/+200	30	DN 2" - AP60	300	AVA Ratingen GERMANY
98	<b>GAS CALDI</b> <i>HOT GAS</i>	450	33	3/4"	800	E.N.E.L. Brindisi
99	<b>GAS DI ALTOFORNO</b> <i>BLAST FURNACE GAS</i>	250/500	Atm	DN 14"x10" - APT3	PN 10	ALFA VALVOLE Srl Casorezzo (MI)
100	<b>GAS DI COMBUSTIONE</b> <i>EXHAUST GAS</i>	-20/+77	41,4	3" - 3 vie 3" - 3 way	300	GROVE ITALIA Voghera
101	<b>GAS DI COMBUSTIONE + CENERI + OLIO</b> <i>EXHAUST GAS + ASH + OIL</i>	450	1,3	3/4" SAT3	150	E.N.E.L. Brindisi



Pos.	Servizio <i>Service Conditions</i>	Temp. (°C)	Press. (bar)	Tipo valvola <i>Valve size and Model</i>	Classe <i>Class</i>	Cliente <i>Client</i>
102	<b>GAS DI COMBUSTIONE + CENERI</b> <i>EXHAUST GAS + ASH</i>	850 700	12	3/4" - 1 1/2" - 2" SAT3 1" - 2" SAT3	600 150	ENIRICERCHE ENI Research Laboratory
103	<b>GAS DI SCARICO</b> <i>EXHAUST GAS</i>	450		1"	150	PNEUMATICA INDUSTRIALE
104	<b>GAS DI TORCIA</b>  <i>FLARE GAS</i>	370	43	DN1"	600	PETRO CHINA DAQING OIL FIELD Methyl Alcohol Plant Ammonia Tech.Revamping PEOPLE'S REP. OF CHINA
105	<b>GAS / POLVERE</b> <i>GAS / ASH</i>	650		1/2"	300	I.E.A.
106	<b>GASOLIO</b> <i>DIESEL OIL</i>	300	3 - 16	DN 1/2" - AP20P	150	ASEKO OY Masala FINLAND
107	<b>GASOLIO</b> <i>GASOIL</i>	306	100	DN10" SAT	1500	MOTOR OIL HELLAS GREECE
108	<b>GLICOLE</b> <i>GLYCOL</i>	300		DN 1.1/2" - AP60	PN 40	PRINCO SRL Parre (BG)
109	<b>GLICOLE</b> <i>GLYCOL</i>	50	3	DN 1" - AP64	150	ALFA VALVOLE Srl Casorezzo (MI)
110	<b>GLICOLE CONDENSATE</b> <i>GLYCOL CONDENSATE</i>	-65	290 Psi	8"	600	BRITISH GAS CORPORATION UK
111	<b>GRASSI ACIDI</b> <i>ACID GREASES</i>	180	1	DN50 / 80 / 100 - AP10NU	PN 16	MATERIA HNOS SACIF ARGENTINA
112	<b>GREGGIO</b> <i>OIL</i>	200	5,8	DN 14" - APT3 -	150	AGIP PETROLI P.to Marghera (VE)
113	<b>HC + H2S</b> <i>HC + H2S</i>	150	14	DN 3" - AP64 -	150	AGIP PETROLI P.to Marghera (VE)
114	<b>H2</b> <i>H2</i>	Amb.	50	DN 4" - APT2	PN 100	ALFA VALVOLE Srl Casorezzo (MI)
115	<b>H2 + H2S</b> <i>H2 + H2S</i>	60	30	DN 2" - AP60	300	AGIP PETROLI P.to Marghera (VE)
116	<b>H2 + HCL</b> <i>H2 + HCL</i>	60	28	DN 2" - AP60	300	AGIP PETROLI P.to Marghera (VE)
117	<b>H2O</b> <b>(50.000 / 70.000 manovre anno)</b> <i>WATER</i> <i>(50.000 / 70.000 operation per year)</i>	20	150	4"	1500	ARMATUR TECKNIK LINKOPING (SW)
118	<b>H2O DI ALIMENTO</b> <i>FEED WATER</i>	185	120	3"	900	E.N.E.L. Ostiglia (MN)
119	<b>H2O DI ALIMENTO</b> <i>FEED WATER</i>	271	90	3"	900	FINCANTIERI
120	<b>H2O DI ALIMENTO TURBINA</b> <i>FEED WATER</i>			1" - 1 1/2"		E.N.E.L. Brescia
121	<b>H2O VAPORE +</b> <b>H2O SOLFORATO + NH3</b> <i>H2O STEAM + H2O SULPHURATED + NH3</i>	140		da 1 1/2" a 6" <i>from 1 1/2" to 6"</i>	150	AGIP PETROLI Sannazzaro de' Burgundi (PV)
122	<b>H2S + CLORURI</b> <i>WET H2S + CHLORIDE</i>	135		2"		BRITISH PETROLEUM INTERNAT.
123	<b>H2S+CO2+H2O+SO2+S2+H2+CO</b> <i>H2S+CO2+H2O+SO2+S2+H2+CO</i>	320	0,5	DN 1" -2" - AP11N -	PN16	MAPOL SPOL S.R.O. Praga (Rep. Ceca)
124	<b>IDROCARBURI + H2S</b> <i>HYDROCARBONS + WET H2S</i>	450		4"	300	SASOL SOUTH AFRICA
125	<b>IDROCARBURI</b> <i>HYDROCARBONS</i>	-100	505	3/4" - 1 1/2"	API 10000	MARATHON OIL
126	<b>IDROCARBURI</b>  <i>HYDROCARBONS</i>	-101/+82	20	DN6" SAT crio	300	CHINA PETROLEUM - LANZHOU ETHYLENE PROJECT PEOPLE'S REP. OF CHINA
127	<b>IDROCARBURI</b> <i>HYDROCARBONS</i>	300	10	1"	150	TECHNOVALVE B.V.



Pos.	Servizio Service Conditions	Temp. (°C)	Press. (bar)	Tipo valvola Valve size and Model	Classe Class	Cliente Client
128	<b>IDROCARBURI</b> HYDROCARBONS	500	20	1/2"	800	ATS
129	<b>IDROCARBURI</b> HYDROCARBONS	250	208	9 mm		ENGIMAT
130	<b>IDROCARBURI</b> HYDROCARBONS	400	74	6" - 3 vie 6" - 3 way	600	ENICHEM ANIC
131	<b>IDROCARBURI</b>  HYDROCARBONS	424	6,4	coppie 6"-3 vie comando simultaneo 6" - 3 way change over unit	300	MEDITERRANEA SpA  MILAZZO
132	<b>IDROCARBURI</b> HYDROCARBONS	180	184	4"	1500	SHELL NORTH CORMORANT PLATFORM
133	<b>IDROCARBURI</b> HYDROCARBONS			da 6" a 14" from 6" to 14"	1500	MARATHON OIL
134	<b>IDROCARBURI LIQUIDI</b> HYDROCARBONS LIQUID	0 / 110	2 - 5	DN 2" - AP60	300	ASEKO OY Masala FINLAND
135	<b>IDROCARBURI LIQUIDI</b> HYDROCARBONS LIQUID	0 / 110	7 - 16	DN 1" - AP20P	150	ASEKO OY Masala FINLAND
136	<b>IDROCARBURI LIQUIDI</b> HYDROCARBONS LIQUID	-120/+170	4	da 1 1/2" a 2" from 1 1/2" to 2"	300	MOSEL BAY - ONSHORE PROJECT SOUTH AFRICA
137	<b>IDROCARBURI + ACQUA</b> HYDROCARBONS + WATER	400	83	1/2" - 3/4"	1500	E.G.P.C. PETROBEL EGITTO
138	<b>IDROCARBURI</b> HYDROCARBONS			from OD 38 to OD 48 DN 15	API 5000 PN250	NORSKE NYDRO BRAGE PROJECT
139	<b>IDROCARBURI + CARBONE (parti)</b> HYDROCARBONS + COAL PARTICLES	650	3,5	1" SAT3	300	DOW CHEMICAL
140	<b>IDROCARBURI</b> HYDROCARBONS	110	17	1" 2" AP20P	800 150	ASEKO OY HELSINKY (SF)
141	<b>IDROCARBURI + BENZOLO</b> HYDROCARBONS + BENZOL	-47/+120	7	DN 2" - AP64	150	AVA RATINGEN - GERMANY
142	<b>IDROCARBURI + CH4 + N2</b> HYDROCARBONS + CH4 + N2	-47/+120	87	DN 2" - AP606	600	AVA RATINGEN - GERMANY
143	<b>IDROCARBURI + CH4 + N2 + C2H4 + C3H8</b> HYDROCARBONS + CH4 + N2 + C2H4 + C3H8	-105		DN 6" - SAT CRIO	150	AVA RATINGEN - GERMANY
144	<b>IDROCARBURI + CH4 + C2H6 + HC + C2</b> HYDROCARBONS + CH4 + C2H6 + HC + C2	-70		DN 6" - SAT CRIO	300	AVA RATINGEN - GERMANY
145	<b>IDROGENO</b> HYDROGEN	20	200	3/4" - 1 1/2"		FIRMANI Genova
146	<b>IDROGENO</b> HYDROGEN	150°F	3256 PSIG	2" - 4" - 6" D.B. & B.	1500	PETRO-CANADA LAKE ONTARIO
147	<b>IDROGENO</b> HYDROGEN	300	100	DN 1" - SAT	PN250	SIEKMANN & CO GMBH Dortmund (Germany)
148	<b>IDROGENO</b> HYDROGEN	120		DN 8" - SAT	150	RAFFINERIA DI MILAZZO SPA Milazzo (ME)
149	<b>IDROGENO</b> HYDROGEN	60	120	DN 1 1/2" - SAT	900	VIRGO ENGINEERS LTD India
150	<b>IDROGENO</b> HYDROGEN	-184		DN 1" / 2" / 6" - SAT crio	150	MTBE MALESIA
151	<b>IDROGENO</b>  HYDROGEN	-170/+66	48	DN 6" DN 3" SAT crio	600	CHINA PETROLEUM - LANZHOU ETHYLENE PROJECT CHINA
152	<b>IDROGENO + ALDEIDI</b> HYDROGEN + ALDEYDE	400	69,5	1/2"	900	ENICHEM AUGUSTA AUGUSTA
153	<b>IDROGENO + H2S</b> HYDROGEN + H2S	50/70	56	6" - 8" 4" - 6" - 8"	300 600	AGIP PETROLI TARANTO
154	<b>IDROGENO + PARAFFINA</b> HYDROGEN + PARAFFIN	550	7	1/2"	300	ENICHEM AUGUSTA AUGUSTA
155	<b>IDROSSIDO DI SODIO</b> SODIUM AQUEOUS HYDROXIDE			1"	600	TROUVAY & CAUVIN





Pos.	Servizio <i>Service Conditions</i>	Temp. (°C)	Press. (bar)	Tipo valvola <i>Valve size and Model</i>	Classe <i>Class</i>	Cliente <i>Client</i>
156	<b>INCHIOSTRI SPORCHI ED ABRASIVI</b> <i>DIRT AND ABRASIVE INK</i>	300	3	DN4" AP10NU	PN16	FLUIDOMATIC SRL Cazzago San Martino (BS)
157	<b>ISOBUTENE - ETILENE</b> <i>ISOBUTENE + ETHYLENE</i>	150	55	DN 1" - 3WAY-Y	600	TRANSMARK S.A. SCHOTEN (Antwerp) BELGIUM
158	<b>KEROSENE</b> <i>KEROSENE</i>	250		1½" - 2"	1500	LUCAS AEROSPACE
159	<b>LATTICI CARBOSSILATI</b> <i>CARBOXILATE LATEX</i>	120		da 2" a 6" - seggi integrali <i>from 2" to 6" - integral seats</i>	300	ENICHEM ANIC Ravenna
160	<b>LETTO FLUIDO PRESSURIZZATO BOLLENTE</b> <i>PRESSURIZED BOILED FLUID BED</i>		12	6"	300	ENIRICERCHÉ S. Donato Mi. (MI)
161	<b>LPG</b> <i>LPG</i>	AMB.		2"	300	AGIP PETROLI Sannazzaro de' Burgundi (PV)
162	<b>METANO</b> <i>METHANE</i>	260	220	DN 1/2" e 3/4" - AP20P	800 Lb	TOMASO FERRARIO1885 SNC Bologna
163	<b>METANOLO</b> <i>METHANOL ALCOHOL</i>	50	290 PSI	8"	600	BRITISH GAS CORPORATION
164	<b>METIONINA</b> <i>METHIONINE</i>			2" (valvola sperimentale) <i>2" (experimental valve)</i>	150	ENICHEM ANIC S. Donato Mi. (MI)
165	<b>MISCELA ACQUA/CARBONE</b> <i>COAL/WATER SLURRY</i>	200	25	3" SAT3	300	ENEL C.R.T.N. Pisa
166	<b>MISCELA ACQUA/CARBONE</b> <i>COAL/WATER SLURRY</i>	200	25	1"	800	C.I.S.E. Segrate (MI)
167	<b>MISCELA DI GAS</b> <i>GAS SLURRY</i>	360	40	2"	300	IMPIANTI SISTEMA GEL Milano
168	<b>MONOSSIDO DI CARBONIO</b> <i>CARBON MONOXIDE</i>	300	9	1"	300	HUMIDRYER ITALIANA Novara
169	<b>NAFTA</b> <i>NAPHTHA</i>	145/220	220/840 KPA	½" - 1" 2" - 3" - 4" - 6"	800 150	ASEKO OY HELSINKY (SF)
170	<b>NATURAL GAS</b> <i>NATURAL GAS</i>	-50/+80		1½"	API 10000	AGIP GAS
171	<b>NATURAL GAS</b> <i>NATURAL GAS</i>	-46/+55	230	6"	900	TOTAL OIL MARINE
172	<b>NATURAL GAS</b> <i>NATURAL GAS</i>	-50		12" - 18"	900	BRITISH GAS CORPORATION
173	<b>NEROFUMO DI GAS</b> <i>CARBON BLACK</i>	450		4"	300	PHILLIPS CARBON BLACK ITALIANA - Ravenna
174	<b>OLIGOMERO</b> <i>OLIGOMER</i>	285	10	DN 2" AP11N	PN40	ITALPET PREFORME SPA Verbania Pallanza (NO)
175	<b>OLIO</b> <i>OIL</i>	205	217	DN 12" - APT3 -	150	AGIP PETROLI P.to Marghera (VE)
176	<b>OLIO + ALLUMINA</b> <i>OIL + ALUMINA</i>	300	10	DN 1" - SAT3 DN 1" - AP60	PN 40 PN 40	CISE SPA Segrate (MI)
177	<b>OLIO AROMATICO</b> <i>AROMATIC OIL</i>	300	25	1" - 3 vie 1" - 3 way	600	PHILLIPS CARBON BLACK ITALIANA - Ravenna
178	<b>OLIO COMBUSTIBILE</b> <i>FUEL (BLENDED OIL)</i>	130	15	1"	300	E.N.E.L. - Centrale S.GILLA
179	<b>OLIO COMBUSTIBILE</b> <i>FUEL (BLENDED OIL)</i>	150	30	DN 4" - AP60 -	300	AGIP PETROLI Priolo (SR)
180	<b>OLIO DIATERMICO</b> <i>DIATHERMIC OIL</i>	220	250	½" - 1"	2500	DIEFFE Cesano Boscone (MI)
181	<b>OLIO DIATERMICO</b> <i>THERMAL OIL</i>	350		da ½" a 2" - 4 vie <i>from ½" to 2" - 4 way</i>	150	COMTEA SpA Carate Brianza
182	<b>OLIO DIATERMICO</b> <i>THERMAL OIL</i>	350	6	DN 2" - 3WAY-Y	PN 40	AKZO NOBEL Arese (MI)
183	<b>OLIO DIATERMICO</b> <i>THERMAL OIL</i>	290	5	DN 2" - AP64	150	RACCORVENETA Marghera (VE)
184	<b>OLIO DIATERMICO</b> <i>THERMAL OIL</i>	300	3	DN 2" - AP10NU DN 3" - AP60	PN 40 PN 40	AGIP PETROLI Marghera (VE)



Pos.	Servizio Service Conditions	Temp. (°C)	Press. (bar)	Tipo valvola Valve size and Model	Classe Class	Cliente Client
185	<b>OLIO DIATERMICO</b> THERMAL OIL	350	6	DN 2" - 3WY- DN 3" - AP60	PN 40 PN 40	AKZO NOBEL Arese (MI)
186	<b>OLIO DIATERMICO</b> THERMAL OIL	280/400	6	DN 3" - AP 60-	PN 40	TECNOSERVICE SNC Oriago (VE)
187	<b>OLIO TERMICO SHELLSOL</b> SHELLSOL THERMIC OIL	160	5	DN4"	PN16	TRANSMARK NV BELGIUM
188	<b>OLIO VEGETALE</b> VEGETABLE OIL	220	0,2	DN 3" e 4" - AP10NB	PN 16	ANDREOTTI IMPIANTI SPA Sesto Fiorentino (FI)
189	<b>OLIO VEGETALE</b> VEGETABLE OIL	200	vacuum	DN 4" - AP10NB	PN 16	FERRERO SPA Alba (CN)
190	<b>OSSIDI DI ALLUMINIO</b> ALUMINIUM OXIDE	650	2755 KPA	3"	600	FLEXITALLIC GASKETS AFRICA LTD
191	<b>OSSIDO DI CARBONIO</b> CARBON OXIDE	300	10	1"	300	HUMIDRYER ITALIANA Novara
192	<b>OSSIDO DI ETILENE</b> ETHYLENE OXIDE	180	0 / 9	DN 2" AP11NB	PN40	FLUIDOMATIC SRL Cazzago San Martino (BS)
193	<b>OSSIGENO LIQUIDO</b> OXYGEN (LIQUID)	-200	1,5	da 1" a 3" SAT CRIO from 1" to 3"	300	P.G.C. Salerno
194	<b>OSSIGENO LIQUIDO</b> OXYGEN (LIQUID)	-200	36	da 2" a 4" SAT CRIO from 2" to 4"	300	S.O.L. Piombino (LI)
195	<b>PETROLIO</b> CRUDE OIL	180		1"		BITUMOIL Milano
196	<b>PLASTICHE FUSE</b> PLASTICS (MOLTEN)	350		2"	150	I.C.I. PLASTICS DIVISION
197	<b>POLIMERI</b> POLYMER	320	6	1½" - 3 vie incamiciate - flang. 2" fluido in camicia: vapore a 60 bar 1½" - 3 way jacketed - flang. 2" medium in jacket: steam at 60 bar	600	ENICHEM FIBRE Pisticci
198	<b>POLIMERI</b> POLYMER	380	10	2" - 3 vie incamiciate - flang. 4" Fluido in camicia: vapore a 320°/70 bar 2" - 3 way jacketed - flang. 4" In jacket: steam at 320°/70 bar	600	ENICHEM FIBRE Pisticci
199	<b>POLIPROPILENE</b> POLYPROPYLENE			3" - 3 vie	600	TECNIMONT Milano
200	<b>POLIPROPILENE</b> POLYPROPYLENE			3/4" - 4"	300	AGIP PETROLI Sannazzaro de' Burgundi (PV)
201	<b>POLIPROPILENE</b> POLYPROPYLENE	380		1" - 3" - 6" / 3 vie	150	SASOL
202	<b>POLIPROPILENE</b> POLYPROPYLENE			1"	600	I.P.V. Ltd South Africa
203	<b>POLIPROPILENE</b> POLYPROPYLENE	200	25	3"	150	EXXON CHEMICAL Rotterdam (NL)
204	<b>POLIPROPILENE</b> POLYPROPYLENE	-48	60	da ½" a 4" jacketed DN 1/2" e 1" - AP 606-	150 600	OY KONWELL AB Helsinki - Finland
205	<b>POLVERINO DI CARBONE FINO</b> FINE COAL DUST	170	50	2"	600	INDUSTRIALE CHIMICA Srl
206	<b>PROPANO GASSOSO</b> PROPANE GAS			6"	300	VISCOLUBE ITALIANA Pieve Fissiraga
207	<b>PROPANO + PROPILENE</b> PROPANE + PROPYLENE			3"	300	TECHINT SPLITTER PLANT
208	<b>PROPENE</b> PROPENE	100	25	DN 2" - 3WT-	300	AHF INDUSTRIES Singapore
209	<b>PROPILENE</b> PROPYLENE	-105		DN2" - SAT crio -	300	INNOVENE SOLVAY Rosignano Sovay (LI)
210	<b>RESIDUI DI SODIO</b> SODIUM SLURRIES	330		da ½" a 6" from ½" to 6"	600	FLUOR



Pos.	Servizio <i>Service Conditions</i>	Temp. (°C)	Press. (bar)	Tipo valvola <i>Valve size and Model</i>	Classe <i>Class</i>	Cliente <i>Client</i>
211	<b>RESIDUO VACUUM</b> <i>THERMALLY CRACKED VACUUM RESIDUE</i>	455		1"	600	TEXACO
212	<b>RESIDUO VACUUM</b> <i>THERMALLY CRACKED VACUUM RESIDUE</i>	430	44.5	3/4" - 6" - 8"	600	AGIP PETROLI Sannazzaro de' Burgundi (PV)
213	<b>RESIDUO VACUUM</b> <i>VACUUM BTM</i>	415	3,5	DN10" SAT	300	MOTOR OIL HELLAS GREECE
214	<b>RESINE IDROCARBURICHE</b> <i>HYDROCARBON RESINS</i>	350	22	1/2" <i>wb jacketed</i>	600	ENICHEM ANIC S. Donato Milanese (MI)
215	<b>RIGENERAZIONE CONTINUA U.O.P. CON IDROGENO</b> <i>U.O.P. CONTINUOUS REGENERATION WITH HYDROGEN</i>	350		da 2" a 6" <i>from 2" to 6"</i>	800	AGIP PETROLI Sannazzaro de' Burgundi (PV)
216	<b>SALI PER TRATTAMENTI TERMICI</b> <i>SALTS (HEAT TREATMENTS)</i>	480	2	3"	300	I.C.I. MOND DIVISION
217	<b>SHELL CRIO TEST</b> <i>SHELL CRIO TEST</i>	-196		DN2" - SAT crio -	600	KITZ CORPORATION OF JAPAN JAPAN
218	<b>SODIOAMMIDE LIQUIDO</b> <i>SODIUM AMMIDE (LIQUID)</i>	400		2"	150	I.C.I. MOND DIVISION
219	<b>SOSPENSIONE DI POLIETILENE CON ISOBUTANO</b> <i>POLYTHENE SUSPENSION WITH ISOBUTANE</i>	150	45	DN25 - SAT	PN100	INNOVENE SOLVAY Rosignano Solvay (LI)
220	<b>SPHERILENE + GAS DI PROCESSO</b> <i>SPHERILENE + PROCESSING GAS</i>	180	28	DN 2" - W1	300	MONTELL ITALIA Ferrara
221	<b>STIRENE (crudo)</b> <i>STYRENE (crude)</i>	50	6	da 1/2" a 2" - seggi integrali <i>from 1/2" to 2" - integral seats</i>	150	DOW CHEMICAL THE NETHERLANDS
222	<b>TETRACLORURO DI CARBONIO</b> <i>CARBON TETRACHLORIDE (CCl4)</i>	585	18	3/4"	600	AGIP PETROLI Porto Marghera (VE)
223	<b>TRICLOROETANO</b> <i>TRICHLOROETHANE</i>	280		da 2" a 6" - seggi integrali <i>from 2" to 6" - integral seats</i>	300	ENICHEM ANIC Ravenna
224	<b>UREA</b> <i>UREA PLANT</i>			1" - 6"	2500	TECHNIPETROL SOMALIA
225	<b>VAPORE</b> <i>STEAM</i>	420	35	DN4" SAT	900	KHARTOUM REFINERY COMANY SUDAN
226	<b>VAPORE</b> <i>STEAM</i>	300	15	1/2" - 1" - 1 1/2"	300	E. N. E. L. - Centrale S. GILLA
227	<b>VAPORE</b> <i>STEAM</i>	300	30	1"	300	PHILLIPS CARBON BLACK ITALIANA - Ravenna
228	<b>VAPORE</b> <i>STEAM</i>	400	160	3/4"	1500	C. I. S. E. Segrate (MI)
229	<b>VAPORE</b> <i>STEAM</i>	350	155	3"	1500	C. I. S. E. Segrate (MI)
230	<b>VAPORE</b> <i>STEAM</i>	126	2,5	1 1/2"	150	DOW LEPETIT Fombio (MI)
231	<b>VAPORE</b> <i>STEAM</i>	280	5 / 6	3/4"	150	ACETATI Srl Verbania (CO)
232	<b>VAPORE</b> <i>STEAM</i>	310	100	da 1/2" a 4" <i>from 1/2" to 4"</i>	1500	SIET (Impianto SPES) Piacenza
233	<b>VAPORE</b> <i>STEAM</i>	139	3,5	DN 2" - AP64 -	150	ASEKO OY Helsinki
234	<b>VAPORE</b> <i>STEAM</i>	225		DN 1" - AP60 -	300	TORMENE Due Carrare (PD)
235	<b>VAPORE</b> <i>STEAM</i>	270	60	DN 4" - SAT1 -	PN100	LONZA SPA S. Giovanni Valdarno (AR)
236	<b>VAPORE</b> <i>STEAM</i>	370	15,2	DN 3" - AP60 -	300	AGIP PETROLI P.to Marghera (VE)

# Reference list



Pos.	Servizio Service Conditions	Temp. (°C)	Press. (bar)	Tipo valvola Valve size and Model	Classe Class	Cliente Client
237	<b>VAPORE</b> STEAM	300	15,2	DN 6" - SAT -	300	AGIP PETROLI P.to Marghera (VE)
238	<b>VAPORE</b> STEAM	400	3,5	DN 12" - SAT APT3 -	150	AGIP PETROLI P.to Marghera (VE)
239	<b>VAPORE</b> STEAM	288	73	DN 2" - AP10HP -	PN160	CMB S.p.A. Pomezia (Roma)
240	<b>VAPORE</b> STEAM	300	11	DN 2" - AP68 -	PN16	AVA MBH Ratingen (Germany)
241	<b>VAPORE</b> STEAM	370	50	DN 6" - SAT	600	EURALLUMINA Porto Scuso (CA)
242	<b>VAPORE</b> STEAM	370	35	DN 2" - SAT -	300	ABB COMBUSTION ENGINEERING Milano
243	<b>VAPORE</b> STEAM	288	80	DN 1/2" e 1" - AP10HP -	600	CMB S.p.A. Pomezia (Roma)
244	<b>VAPORE</b> STEAM	200	18	DN 1 1/2" - AP60 -	PN 40	AKZO NOBEL CHEMICALS SPA Arese (MI)
245	<b>VAPORE</b> STEAM	280	5	DN 1" - SAT -	PN 16	ACETATI SPA Verbania
246	<b>VAPORE</b> STEAM	255	17	DN 12" - SAT -	300	DRESSER ITALIA Casavatore (NA)
247	<b>VAPORE</b> STEAM	220	6	DN 1" - AP20P -	6000psi	ALFA VALVOLE Casorezzo (MI)
248	<b>VAPORE</b> STEAM	230	25	DN 1" - SAT -	300	VIRGO ENGINEERS LTD India
249	<b>VAPORE (Spillamento campioni)</b> STEAM (Sampling)	270	180	1/2"	1500	E. N. E. L. Ostiglia (MN)
250	<b>VAPORE (tempo di manovra 2 sec)</b> STEAM (operation in 2 sec)	370	50	6" - By-pass turbina 6" - Turbine by-pass	600	EUROALLUMINA Porto Scuso (CA)
251	<b>VAPORE SATURO</b> STEAM	211	20	da 1/2" a 3" from 1/2" to 3"	600	FABBRICA ADESIVI RESINE Milano
252	<b>VAPORE SURRISCALDATO</b> STEAM (SUPERHEATED)	480	45	da 1/2" a 3" from 1/2" to 3"	600	FABBRICA ADESIVI RESINE Milano
253	<b>VAPORE SURRISCALDATO</b> STEAM (SUPERHEATED)	420	145	1/2" - 3/4" - 1"	1500	E. N. E. L. - Centrale OSTIGLIA
254	<b>VAPORE + RISO SOFFIATO</b> STEAM + PUFFED RICE	180	15	DN 6" - AP10 -	150	R. I. S. A. Srl Rozzano (MI)
255	<b>VAPORE + TDI + DCB</b> STEAM + TDI + DCB	320	30	da 1 1/2" a 3" from 1 1/2" to 3"	300	MONTEDISON DIPI FOMBIO
256	<b>VAPORE + H2S + AMMONIACA</b> STEAM + H2S + AMMONIA	80/120	3	2" - 4" - 6"	150	AGIP PETROLI Sannazzaro de' Burgundi (PV)
257	<b>VAPORE + SODA</b> STEAM + SODA	247	40	DN 1 1/2" - SAT -	300 600	EURALLUMINA Porto Scuso (CA)
258	<b>VAPORI DI OLIO DIATERMICO</b> VAPOUR OF HEAT OIL	320		2"	150	I. C. I. MOND DIVISION
259	<b>ZOLFO</b> SULPHUR	300		2" - 3"	300	F. C. C. COMPLEX UNGHERIA
260	<b>ZOLFO FUSO</b> SULPHUR (MOLTEN)	400	2	1" - 2" incamiciate 1" - 2" jacketed	150	I. S. A. B. Priolo Gargallo (SR)
261	<b>ZOLFO FUSO</b>  SULPHUR (MOLTEN)	140		DN 1 1/2" -2"-3"-4" incamiciate -W1J- DN 1 1/2" -2"-3"-4" jacketed -W1J-	150	INFINEUM ITALIA SRL  Vado Ligure (SV)
262	<b>ZOLFO FUSO + GAS DI PROCESSO IN NM3 + HR</b> SULPHUR (MOLTEN) + PROCESS GAS IN NM3 + HR	750	6	2" incamiciate 2" jacketed	300	I. S. A. B. Priolo Gargallo (SR)



## CONDIZIONI GENERALI DI VENDITA – GENERAL CONDITIONS OF SALES

1. Sono accettati esclusivamente ordini provvisti di numerazione e redatti su carta intestata completa di tutti i dettagli fiscali del committente. L'ordine sarà considerato processato solo a seguito di emissione di regolare modulo di conferma d'ordine da parte di Penta Srl, possibile solo dopo l'eventuale completa definizione con il committente di tutti i dettagli non esplicitamente chiariti sullo stesso. La conferma d'ordine si intenderà automaticamente accettata dal committente trascorsi 5 giorni lavorativi dalla sua trasmissione.
2. Non sono accettati ordini di importo inferiore a 300 Euro escluso IVA a meno di specifica autorizzazione da parte della Direzione Generale.
3. I prezzi convenuti saranno considerati fissi ed invariabili per la durata della fornitura e non comprenderanno spese di imballo e trasporto, che saranno esplicitate a parte nelle offerte a meno di accordo diverso in fase di trattativa.
4. Salvo diverso esplicito accordo, i trasporti sono da considerarsi interamente a carico dell'acquirente e la merce si intende compravenduta franco fabbrica dal venditore o FCA (INCOTERMS 2010) nostro stabilimento in Via Boccaccio, 23 – 25080 Mazzano (BS) - ITALY. Qualora l'acquirente incarichi la venditrice di negoziare, per suo conto ed in piena autonomia, i trasporti e gli altri servizi accessori e le modalità della loro realizzazione, ivi compresa eventuale stipulazione di contratto di assicurazione relativo alla merce trasportata, le relative spese verranno addebitate all'acquirente concordemente alla fornitura. La venditrice si intende in ogni caso assolta da ogni responsabilità relativa alla buona esecuzione dei trasporti, dei servizi accessori e dell'assolvimento delle condizioni in assicurazione. Eventuali contestazioni dovranno essere inviate dall'acquirente direttamente al vettore incaricato. La documentazione necessaria ai fini delle pratiche di rimborso assicurativo saranno a totale carico dell'acquirente.
5. Il committente ha tempo 10 giorni lavorativi dalla comunicazione di merce pronta per approntarne il ritiro. Decorso tale termine è facoltà di Penta Srl addebitare i costi di immagazzinamento, comunque non superiori allo 0,5% del valore in fattura moltiplicato per mese o frazione di mese trascorsi all'effettivo ritiro, con valore minimo di 300 Euro.
6. I termini di consegna di cui ai singoli ordini verranno concordati in sede di offerta da parte della venditrice e confermati al momento dell'ordine. Tali termini non devono comunque intendersi perentori e potranno essere prorogati in caso di particolari esigenze di produzione, previo preavviso all'acquirente. Eventuali clausole di penalità per ritardo di consegna dovranno essere concordate in sede d'ordine e non saranno considerate accettate se comunicate posteriormente ad esso.
7. La mancata corresponsione degli importi pattuiti nei termini previsti in ordine comporterà l'addebito degli interessi di mora dell'ordine dello 0,5% mensile, maggiorati delle spese bancarie. Un ritardo di pagamento che superi di 60 giorni le condizioni pattuite in ordine, oltre all'addebito degli interessi cui sopra, darà automaticamente avvio a pratica di recupero legale del credito da parte di primaria organizzazione.
8. Trascorsi 30 giorni dal ricevimento della merce senza alcuna comunicazione, l'acquirente non potrà sollevare alcuna eccezione al fine di ritardare il pagamento.
9. I prodotti si intendono nuovi e realizzati con materiali di costruzione nuovi ed esenti da difetti, utilizzando la buona norma costruttiva e manodopera qualificata, nonché in accordo alle condizioni tecniche, di utilizzo e di documentazione specificate nell'ordine di acquisto. Il periodo di garanzia si intende il più breve tra 12 mesi dalla accettazione della merce da parte del committente e 18 mesi dalla data di spedizione. La garanzia non riguarda tutti quei componenti soggetti ad usura a seguito di movimento qualora la causa sia riconducibile al movimento stesso.
10. Eventuali vizi e difetti del materiale dovranno essere denunciati alla venditrice entro 5 giorni lavorativi dal ricevimento.
11. Tutti i prodotti si intendono venduti con riserva di proprietà e divengono di proprietà del compratore solo all'integrale pagamento del prezzo. L'eventuale accettazione di pagamenti con cambiali od altri titoli di credito non muta il suddetto patto poiché tali titoli si intendono ricevuti "prosolvendo" e non "pro soluto".
12. Eventuali deroghe alle presenti condizioni particolari e generali dovranno essere convenute tra le parti per iscritto.
13. La venditrice si riserva di accettare resi a fronte di prodotti definiti difettosi da parte dell'acquirente solo a seguito di ispezione presso le proprie officine. I materiali resi non saranno accettati qualora gravati da qualsiasi spesa di trasporto.
14. Nell'ipotesi di forniture continuative la venditrice potrà sospendere le forniture stesse nel caso in cui l'acquirente dovesse rendersi inadempiente ad una sola delle condizioni particolari o generali concordate.
15. La documentazione prevista in ordine sarà resa disponibile al Cliente tramite memorizzazione in area riservata del sito [www.pentavalves.it](http://www.pentavalves.it) di cui saranno preventivamente fornite user name e password. La richiesta di copie cartacee di qualsiasi tipo di documentazione sarà soggetta a costi da concordare esclusivamente con l'ufficio commerciale Penta, così come qualsiasi documentazione aggiuntiva non esplicitamente richiesta nell'ordine ed accettata nella conferma d'ordine.
16. Tutti gli ordini ricevuti saranno soggetti alla seguente clausola di cancellazione:

Evento di cancellazione (in % del tempo di consegna)	Valore fatturato
≤20%	20%
20% to 40%	40%
40% to 60%	60%
Over 60%	80%

1. Orders are accepted exclusively equipped with numbering and written on headed paper including all buyer tax details. The order will be considered processed only after the issue of a regular acknowledgement form by Penta Srl, possible only after the complete agreement with customer of all the details not explicitly clarified in the order. The order acknowledgement will be considered automatically accepted by the customer after 5 working days of its submission.
2. Penta Srl will not accept orders with a total amount less than 300 Euro (VAT excluded) unless specific authorization of the General Manager.
3. The agreed prices shall be considered fixed and invariable for the duration of the supply and shall not include packaging and transport costs. These costs will be listed separately in the offers and orders unless different agreement during negotiations.
4. Except different agreement, the transport should be considered borne by the purchaser and the goods will be considered purchased ex works or FCA (INCOTERMS 2010) our factory in Via Boccaccio, 23-25080 Mazzano (BS) - ITALY. If buyer designates the vendor to negotiate on its behalf and in full autonomy transport and other complementary services, including stipulation of insurance contracts covering the transported goods, the corresponding fee will be charged accordingly with the supply. Penta Srl is in any case discharged by all liability relating to well done transport, complementary services and satisfaction of insurance conditions. Any complaint must be sent by the purchaser directly to the carrier or forwarding agent designated. The documentation for the insurance practices will be totally borne by the buyer.
5. Customers have 10 working days from the advice of goods availability to arrange the collection. After that period Penta Srl can charge storage costs, which will not exceed 0.5% of the invoice value multiplied by month or fraction of a month elapsed before collection, with a minimum of 300€.
6. Terms of delivery of individual orders will be agreed during negotiations and confirmed in the purchase order. These terms shall not be considered as fixed and unchangeable and can be modified in case of special production requirements only after a notice to the buyer is provided. Any penalty clauses for late delivery shall be included in the purchase order after specific agreement between the parties. Penalty clauses will be NOT accepted if communicate after the transmission of a valid purchase order.
7. Non-payment of any amounts within the period agreed in the purchase order will cause order default interest charge of 0.5% per month, plus the bank charges. A late payment that exceeds 60 days the conditions agreed in the order will automatically start legal actions by a major organization specialized in credit recovery, in addition to interests charge calculation as mentioned above.
8. After 30 days of receipt of goods without any claim, the buyer cannot raise any objection in order to delay the payment.
9. All products delivered by Penta Srl are new, made with new materials without defects, using good constructive practices and skilled labor, and according to the technical conditions of use and documentation details as specified in the purchase order. The warranty period is defined as the shorter between 12 months from acceptance of the goods by the purchaser and 18 months from date of shipment. Warranty does not cover all the components subject to wear as a result of a valve stroke in case this was due by the movement itself.
10. Any defect or material defect must be reported to the Penta Srl within 5 working days from reception of the valves.
11. All products will be considered sold with retention of title and will become buyer's property after the payment of the complete price. Payments with promissory note or other credit titles does not change the above condition as these titles are received "recourse" and not "without recourse".
12. Any exceptions to these general and particular conditions of sale need to be agreed between the parties in writing.
13. Penta Srl reserves the right to accept products announced with defects only after a full inspection at its plant. Returned materials will not be accepted if burdened by any shipping charge.
14. In case of blanket orders, Penta Srl may suspend the supplies in the event that the buyer does not perform its obligations to one of the specific or general conditions agreed.
15. The required documentation as showed in the purchase order will be made available to the Customer in the reserved area on website [www.pentavalves.it](http://www.pentavalves.it). Username and password will be provided to the customer in the Order Acknowledgment. The request of hard copies of any kind of documentation will be subjected to a charge after agreement with Penta Srl sales office, as well as any additional documentation not explicitly required in the order and accepted in the order acknowledgement.
16. In case of order cancellation Penta Srl will apply the following penalty clause:

Time of cancellation (as % of delivery term)	Inviced value
≤20%	20%
20% to 40%	40%
40% to 60%	60%
Over 60%	80%



**Sede legale e operativa/Headquarters:**

Via Boccaccio 23  
25080 Molinetto di Mazzano (BS) ITALY  
Tel. 030 26 29 175 Fax 030 26 29 176

**Internet:**

[www.pentavalves.it](http://www.pentavalves.it)      [www.stockofvalves.com](http://www.stockofvalves.com)  
[info@pentavalves.it](mailto:info@pentavalves.it)      [info@stockofvalves.com](mailto:info@stockofvalves.com)  
[sales@pentavalves.it](mailto:sales@pentavalves.it)

Follow us on



**Official Page “ Penta Srl Metal Seated Ball Valves”**