

SWING CHECK VALVE DN15 to DN100
- Type 400 -

Description

- **Size** : DN15 to DN100.
- **Connection** : **Screwed-on flanges (PN10/PN16 - PN20 and 300Lbs)** or welded flanges, SW, BW, threaded female.
- **Body seal material**: **25% glass PTFE**, graphite, spiral stainless steel/graphite.
- **Plug sealing**: **Metal/metal**, 25% glass PTFE, hard faced.
- **Wetted materials**: **1.4404 (316L)**, 1.4306 (304L), steel, nickel alloy (inconel, hastelloy, monel, nickel, zirconium...) 904L (uranus), 1.4571 (316Ti), refractory (310), titanium, tantalum.
- **Options** : Heating jacket.

Note : bold, standard parameters.

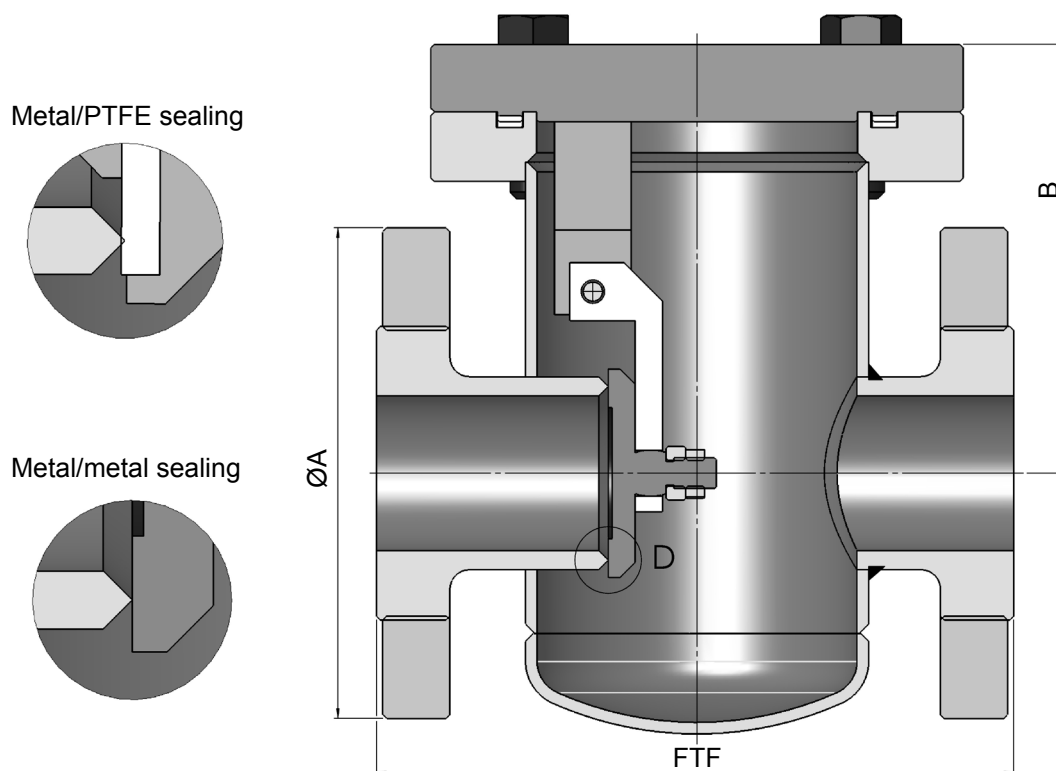

Dimension		DN15	DN20	DN25	DN32	DN40	DN50	DN65	DN80	DN100
A	PN10/16	95	105	115	140	150	165	185	200	220
	PN20	89	99	108	117	127	152	178	190	229
	300Lbs	95	117	124	133	156	165	190	210	254
FTF	PN10/16	130	150	160	180	200	230	290	310	350
	PN20	108	117	127	140	165	203	216	241	292
	300Lbs	152	178	203	216	229	267	292	318	356
B		65	70	70	90	110	130	150	160	170

All other manufacturing are available on request

Non-contractual document

SWING CHECK VALVE DN15 to DN100
- Type 400 -

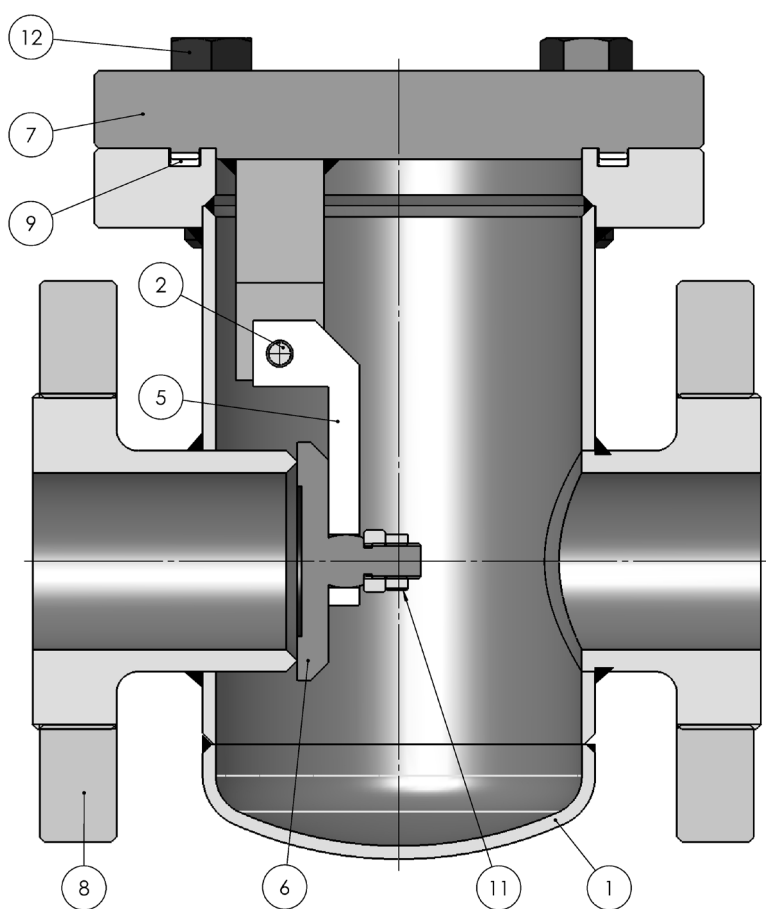

N°	Description	Qty
1	Body	1
2	Joint pin	1
5	Finger	1
6	Seat	1
7	Bonnet	1
8	Flange	2
9	Body gasket	1
11	Nut	2
12	Screw	4

Non-contractual document

Find out more about our check valves:
<http://www.bom.fr/en/check-valve>



Exonder S.r.l.

📍 Via Torre, 2 - 28040 Borgo Ticino (NO) - Italy
 ☎ +39 0321 908466
 ✉ customercare@exonder.it
 🌐 <https://www.exonder.it>

All other manufacturing are available on request